



PRODUCT SPECIFICATION GUIDE

**NEW LINEAR SCREED
DRAIN SECTION
AVAILABLE**

CLICK HERE



PEACE OF MIND
GUARANTEED



Introduction

CCL Wetrooms are the UK's leading wetroom specialist offering a range of innovative products designed to create stylish contemporary wetrooms, backed up by our unique [lifetime guarantee](#).

With over 30 years experience in waterproofing, our unrivalled track record allows us to continually lead the way in wetroom design whilst embracing the latest technology combined with exceptional customer support.

Our comprehensive range of products are designed to offer a variety of solutions for Architects and Designers whilst overcoming the challenges presented by today's modern floor structures.

WHY WE ARE DIFFERENT

CCL Wetrooms understand that creating the perfect wetroom is not just about designing the right product or offering the best service.

We offer our customers a complete wetroom solution which includes design, specification and the option of a fully guaranteed installation, plus full technical support whenever it's required.

Our involvement in a project from conception to completion ensures quality is never compromised.



CCL Wetrooms deliver [peace of mind - Guaranteed](#)





MANUFACTURER

As a leading UK manufacturer our products are designed specifically for the UK market and fully tested to the highest possible standards. Our research and development team are continually innovating and improving, ensuring that we are able to offer a wetroom solution in virtually any situation.

In addition to our own manufactured products we are the exclusive distributors of products such as  Tilesafe and Screedsafe as well as offering other specialist  waterproofing solutions.



DESIGN & SPECIFICATION SERVICE

As part of our commitment to our customers CCL Wetrooms offer a comprehensive professional design and specification service from the planning stages of a project, right through to design and on-site support, including:

- Project design, advice and guidance
- Technical drawings and specification
- On-site training and support
- Bespoke design and manufacture
- CPD based technical seminars



INSTALLATION

Our extensive experience has shown us that some customers desire the peace of mind of having a complete supply and fit service from the manufacturer, therefore ensuring that responsibility for the installation lies at one point. With this in mind we are able to offer a supply and fit service through our sister company  providing the following services;

- Product installation
- 10 year installation guarantee
- Optional 10 year insured guarantee

Advantages of a wetroom

- Stylish, contemporary design providing a luxury feel to any bathroom.
- Efficient use of space creating the feeling of a large open area.
- Easy to use and keep clean with little maintenance required.
- Endless design possibilities by not being limited to set dimensions.
- Accessible for all - allowing bathrooms to meet the latest fully inclusive design criteria and legislation.

Key

We have developed a simple key to help guide you through the product selection process.

Throughout our literature you will find the following symbols indicating key features and benefits:



SUITABLE FOR SOLID FLOORS



MAXIMUM FLOW RATE (L/min)



SUITABLE FOR TIMBER FLOORS



BBA CERTIFICATION



LIFETIME GUARANTEE



BESPOKE DESIGN AVAILABLE



DE-COUPLING PROPERTIES

CONTENTS

SECTION 1 LINEAR DRAINS

NEW LINEAR SCREED DRAIN
SECTION AVAILABLE

[CLICK HERE](#)

SECTION 2 MODULAR WET-FLOOR

2.1 MODULAR WET-FLOOR

SECTION 3 FLOOR FORMERS

3.1 LINEAR WET-DEC

3.2 WET-DEC

SECTION 4 WATERPROOFING

4.1 RIW TILES SAFE

4.2 RIW SCREED SAFE

4.3 RIW FWM

SECTION 5 INSTALLATION

5.1 INSTALLATION

2.1 MODULAR WET-FLOOR

FINISHED PRODUCT



The Modular Wet-Floor system is a unique concept in wetroom technology that can be used in a number of configurations to create a wetroom on a timber floor.

The system is versatile and cost effective and can be installed with the linear drain in either the centre of the shower area, or neatly positioned against the wall.

Consisting of three main elements, the Modular Wet-Floor is simple to configure. Start by selecting the required number of Drainage Components and Tapered Boards, then simply choose the appropriate Floor or Wall Grill to suit your wetroom layout.

The Drainage Component and Tapered Boards can then be easily trimmed on-site, making the whole system quick and easy to install.

KEY FEATURES

- Modular system
- Easily trimmed
- Quick and easy to install
- One or two way fall
- Ideal for large format tiles
- Floor or wall grill option
- Variable waste position
- Flow rate up to 68 L/min
- Height adjustable grill
- Lifetime guarantee

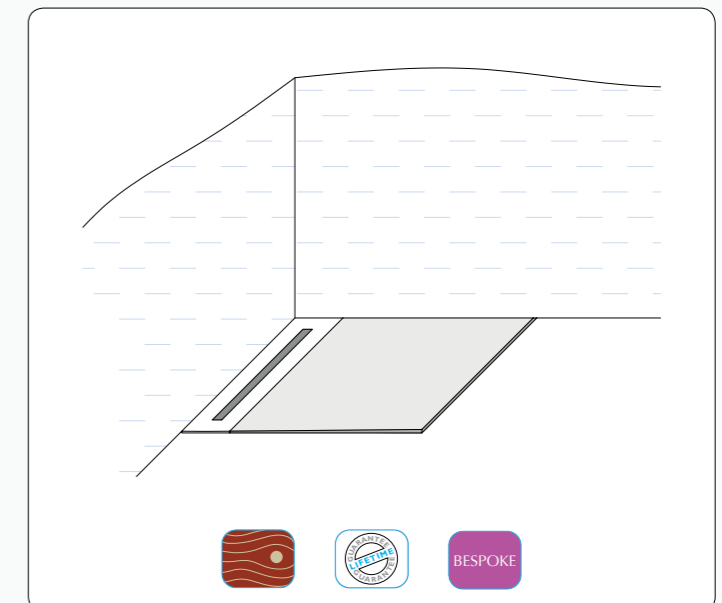

2.1 MODULAR WET-FLOOR

SYSTEM COMPONENTS

The Modular Wet-Floor system comprises of three main elements:

- 1 Drainage Component
- 2 Tapered Board
- 3 Floor/Wall Grill

1 Select the required number of drainage components.

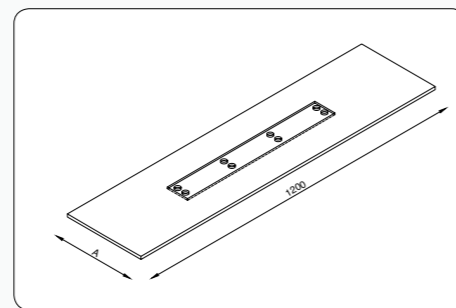

2 Select the required number of Tapered boards.

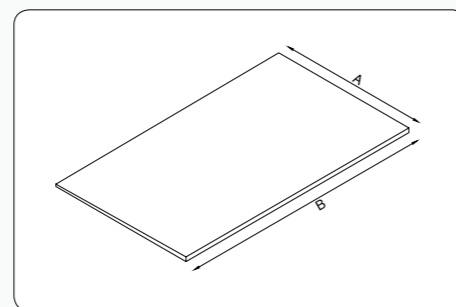

3 Select the appropriate floor or wall grill, along with the correct number of traps depending on the required flow rate.



The drainage component and Tapered boards can then be easily trimmed on site.

2.1 MODULAR WET-FLOOR

1 DRAINAGE COMPONENT

Manufactured from tough ABS plastic, the Drainage Component is the central element of the Modular Wet-Floor; once its position has been decided, the remainder of the system is built around it.

Forming a base for the Linear Drain, the Drainage Component has a 1mm gradient towards the centre and can be installed in either an offset or central position

within the shower area, or neatly up against the wall to create a sleek and unobtrusive wall drain*.

The Drainage Component can be easily trimmed by up to 200mm off each end using a hand saw and is secured using the pre-drilled screw ports.

Two Drainage components can also be butted together to create a larger wetroom area.

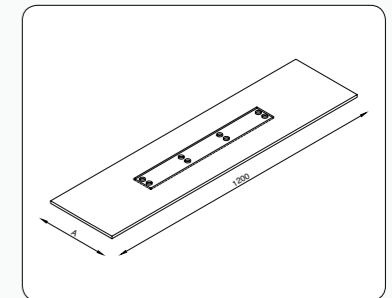

*When installed with the Wall Grill, the Drainage Component width is reduced by 80mm, to 220mm.

The Trap

The trap has an adjustable ball joint and comes with removable dip-tube.

For ease of installation it can be fitted anywhere within the central section of the Drainage Component, making it simple to avoid joists and other such obstructions.

- Floor or wall grill option
- Trimmable
- Variable waste position
- Multi-directional outlet
- 50mm Water seal
- BS1455 / 1566



No. of Traps

A single trapped Modular Wet-Floor has a flow rate of up to 27 L/min*

When a higher flow rate is required an additional trap can be installed, allowing up to 50 L/min*.

For higher flow rates a third trap can be installed giving up to 68 L/min*.

* See flow rate chart for full details.



No. of traps	No. of wastes		
	1	2	3
1	25 L/min	n/a	n/a
2	41 L/min	41 L/min	n/a
3	41 L/min	41 L/min	60 L/min
1	27 L/min	n/a	n/a
2	50 L/min	50 L/min	n/a
3	50 L/min	61 L/min	68 L/min

Stone / Solid-infill
Slotted / Square Holes

2.1 MODULAR WET-FLOOR

2 TAPERED BOARD

The Tapered Boards are manufactured from XPS foam with a mineral coating, making them both lightweight and easy to handle, whilst maintaining good thermal properties and compressive strength.

Each board is 1200mm long and tapered from 22mm to 11mm, giving a consistent gradient every time.

Available in five widths, the boards can be easily trimmed to size using a hand saw and should be secured with the fixing washers supplied, at a minimum of 300mm centres.

The system is designed with versatility in mind and can be installed in a number of different configurations.

See pages 7 to 10 for the most common layouts.

Using a combination of boards, either a one way fall towards the wall, or a two way fall with a central or offset drain can be created. Two or more Tapered Boards can also be butted together to create a larger wetroom area.

A 280mm x 300mm infill panel is available for use in certain configurations.

- Designed for timber floors
- One or two way fall
- Wetroom area can be varied to suit
- Easily trimmed
- Fixing washers included
- Quick and easy to install
- Ideal for large format tiles

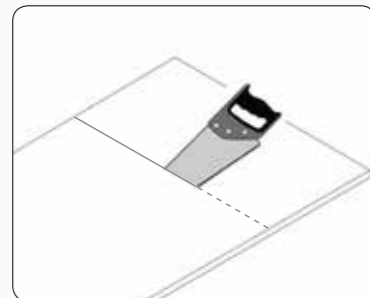
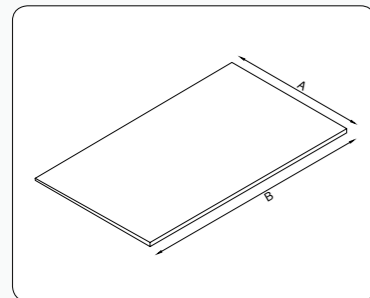

Tapered Boards are available in 6 standard sizes:

A **B**

- 300mm x 1200mm
- 500mm x 1200mm
- 700mm x 1200mm
- 1000mm x 1200mm
- 1200mm x 1200mm
- 1500mm x 1200mm

Infill Panel

- 280mm x 300mm

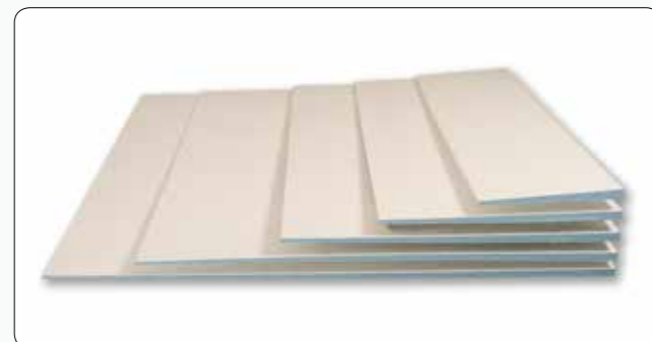

2.1 MODULAR WET-FLOOR

3 GRILL TYPE

There are two types of grill available within the Modular Wet-Floor system, both are designed to fit onto the Drainage Component.

Floor Grill

For installation in either an offset or central position within the shower area.

Grill width 58mm

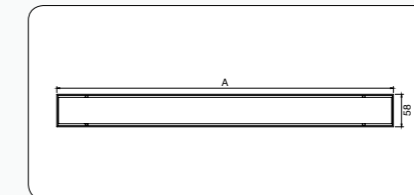

Wall Grill

For installation against the wall.

Grill width 86mm

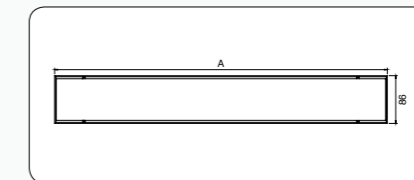

Grill length

The Drainage Component is manufactured with one trough size at 660mm, all lengths of grill are then fitted onto this trough.

The grill is available in nine standard sizes; two grills can be butted together to create a larger wetroom area (excluding 600mm grill).

- 600mm
- 800mm
- 900mm
- 1000mm
- 1100mm
- 1200mm
- 1300mm
- 1400mm
- 1500mm

9 GRILL LENGTHS



Bespoke grills can be manufactured for sizes in between and over those that are standard. Please contact our technical team to discuss your requirements.

2.1 MODULAR WET-FLOOR

3 GRILL TYPE - CONTINUED

Grill Finish

The grill is available in various different finishes.

All are manufactured in 316 marine grade stainless steel, ensuring a stunning high quality finish.

Type A Solid Grill is supplied as standard unless otherwise specified.

Type A - Solid Grill:
Grained stainless steel with a 3mm gap around the grill for a sleek stylish finish.

Type B - Oblong Slots:
Three rows of oblong slots in a grained stainless steel finish.

Type C - Square Holes:
Three rows of squares in a grained stainless steel finish.

Type S - Stone-infill
Allows a section of tile to be inserted to provide a sleek continuous look. Suitable for 10-12mm stone / porcelain tiles. Bespoke depths available to order.



Height & Width adjustment

The grill is height adjustable in 1mm increments to suit tile thicknesses of 6mm to 20mm.

Additional spacers are available upon request for tiles thicker than 20mm.

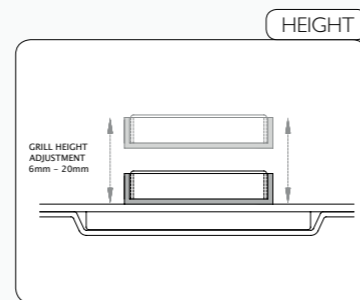

The Wall Grill is width adjustable to allow for different wall tile thicknesses.

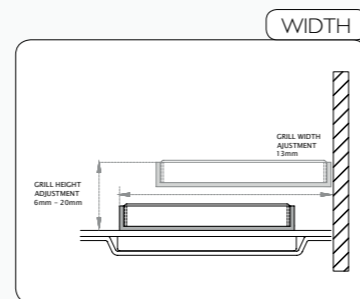

2.1 MODULAR WET-FLOOR

TYPICAL LAYOUTS

The Modular Wet-Floor is an extremely versatile system which can be installed in many possible combinations. The following examples show typical wetroom layouts that can be achieved, for further assistance please contact our technical team who will be pleased to advise.

LAYOUT 1

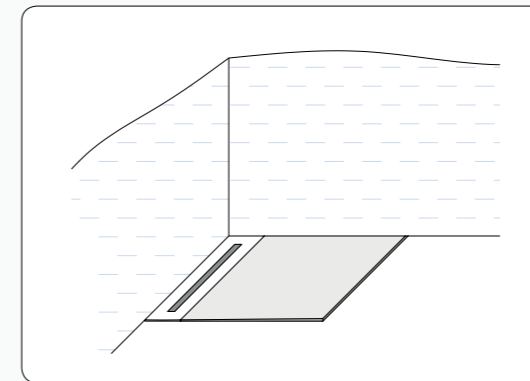

LAYOUT 2

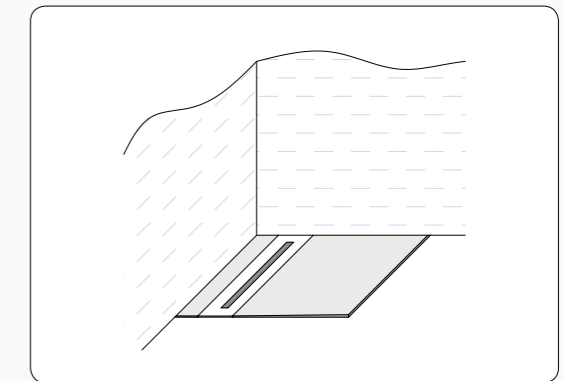

LAYOUT 3

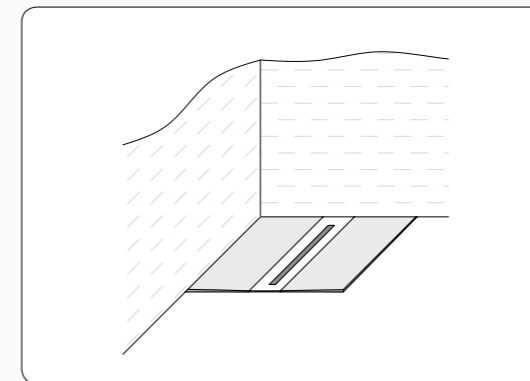

LAYOUT 4

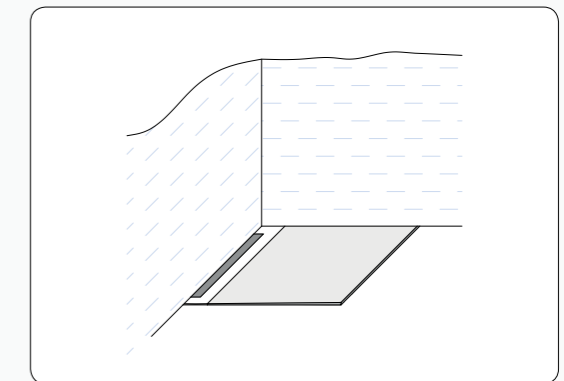

2.1 MODULAR WET-FLOOR

TYPICAL LAYOUTS

Examples showing typical wetroom layouts that can be achieved (continued).

LAYOUT 5

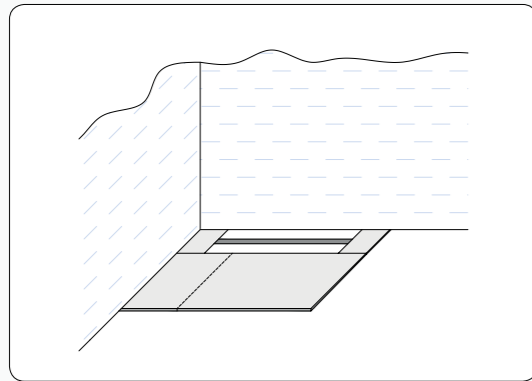

For layout 5 we recommend a maximum width of 1700mm, for widths greater than this use two Drainage Components, as layout 7.

LAYOUT 6

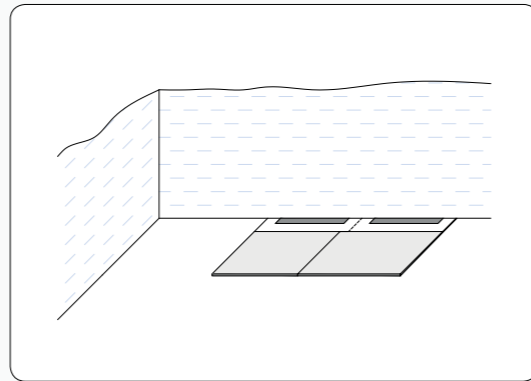

For layout 6 the minimum width required is 1700mm

LAYOUT 7

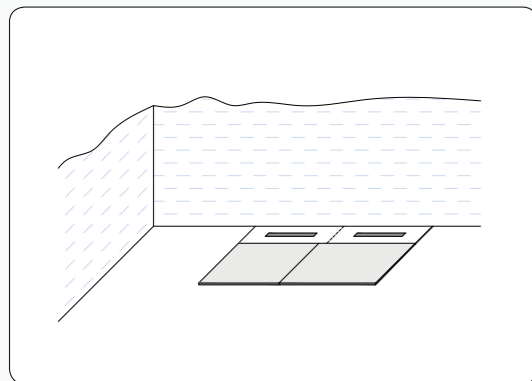

For layout 7 the minimum width required is 1700mm

LAYOUT 8

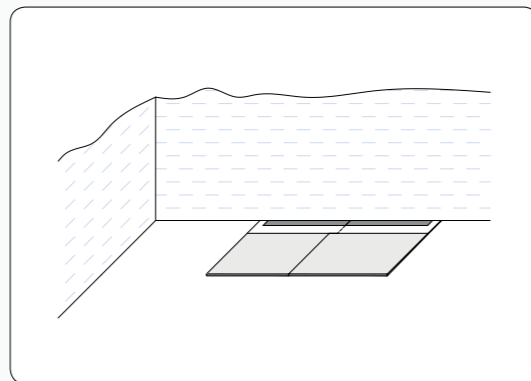

For layout 8 the minimum width required is 1800mm

2.1 MODULAR WET-FLOOR

PRODUCT DETAILS

	IMAGE	DESCRIPTION	SIZE	PRODUCT REF
1 DRAINAGE COMPONENT		Drainage Component with 1 trap. Maximum flow rate 27 L/min	1200mm x 300mm	MDC-1
		Drainage Component with 2 traps. Maximum flow rate 50 L/min	1200mm x 300mm	MDC-2
		Drainage Component with 3 traps. Maximum flow rate 68 L/min	1200mm x 300mm	MDC-3
2 TAPERED BOARD		Tapered board 22mm-11mm	300mm x 1200mm 500mm x 1200mm 700mm x 1200mm 1000mm x 1200mm 1200mm x 1200mm 1500mm x 1200mm	MTB-03 MTB-05 MTB-07 MTB-10 MTB-12 MTB-15
		Infil Panel	280mm x 300mm	MIP-1
3 GRILL TYPE		Floor Grill Type A - Solid*	600mm 800mm 900mm 1000mm 1100mm 1200mm 1300mm 1400mm 1500mm	MFG-06 MFG-08 MFG-09 MFG-10 MFG-11 MFG-12 MFG-13 MFG-14 MFG-15
		Wall Grill Type A - Solid*	600mm 800mm 900mm 1000mm 1100mm 1200mm 1300mm 1400mm 1500mm	MWG-06 MWG-08 MWG-09 MWG-10 MWG-11 MWG-12 MWG-13 MWG-14 MWG-15

*The Type A – Solid Grill is supplied as standard, for alternative grill finishes please see page 6

2.1 MODULAR WET-FLOOR

HOW TO SPECIFY

To specify your Modular Wet-Floor first decide the layout of your wetroom, then simply follow the three step process:

Step **1** Select the required number of Drainage Components and Traps

Step **2** Select the required number and size of Tapered Boards

Step **3** Select the required Floor or Wall Grill

Note: The Drainage Component and Tapered Boards can be easily trimmed on-site.
Two Drainage Components and Grills can be butted together to create a larger wetroom area.

EXAMPLES

EXAMPLE CONFIGURATIONS:

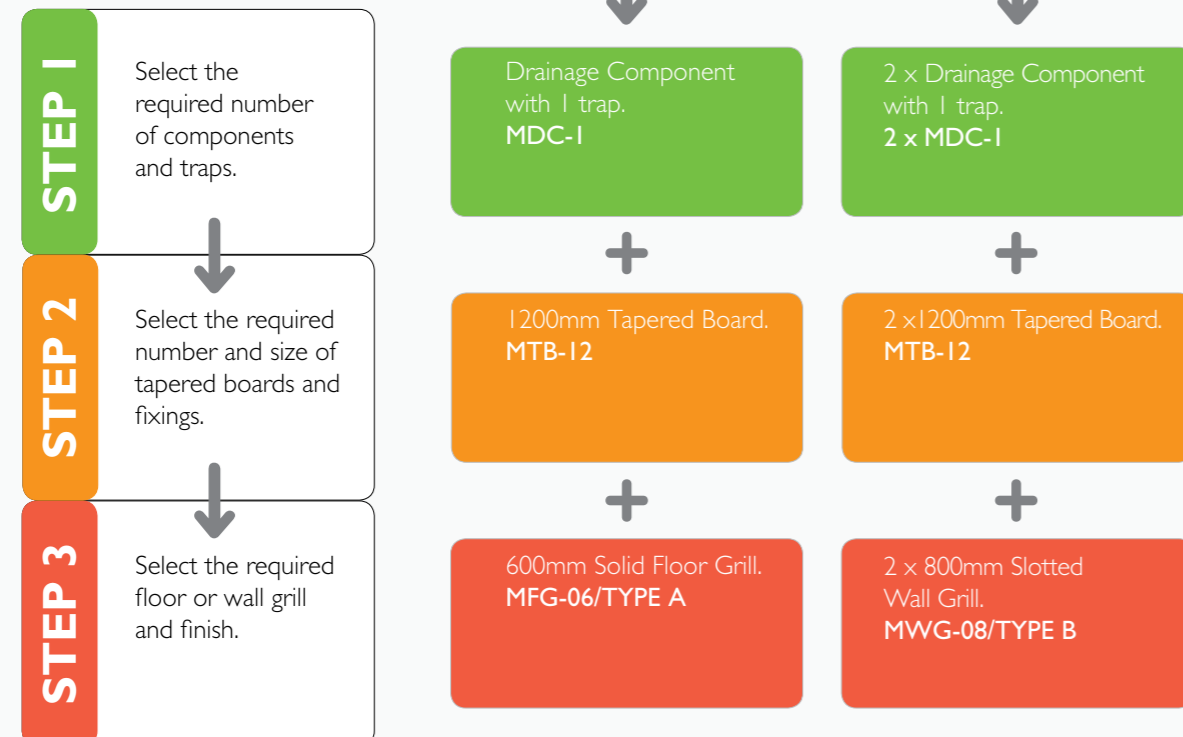

2.1 MODULAR WET-FLOOR

WATERPROOFING

It is essential that the floor is waterproofed or 'tanked' using the following membranes.

IMAGE	DESCRIPTION	PRODUCT REF
	<p>RIW Tilesafe – A superior waterproof membrane designed for use in wetrooms, prior to the application of ceramic tiles and natural stone².</p> <ul style="list-style-type: none"> • Self-adhesive • Lifetime Guarantee • Quick and easy to install • De-coupling and acoustic properties 	<p>TSK-5 (5m² kit)</p> <p>TSK-10 (10m² kit)</p>
	<p>RIW FWM – A liquid membrane designed for waterproofing walls, fully compatible with Tilesafe and Screedsafe².</p>	FWM-8 (8kg)

¹ For full technical details please refer to section 4

For timber floors we would recommend the Tilesafe membrane is applied to the entire wetroom floor.

FWM should then be applied to the walls of the shower area plus an additional 300mm and overlapped onto the Tilesafe Reinforcing Tape.

IN DETAIL

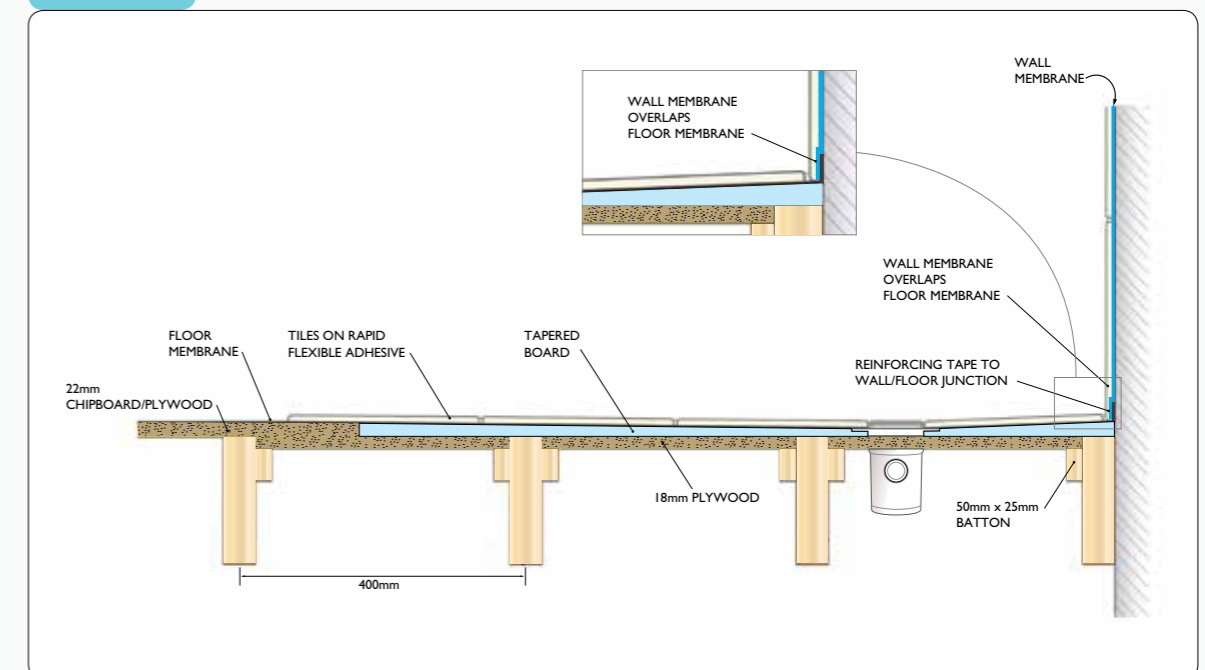

2.1 MODULAR WET-FLOOR

DRAINAGE COMPONENT

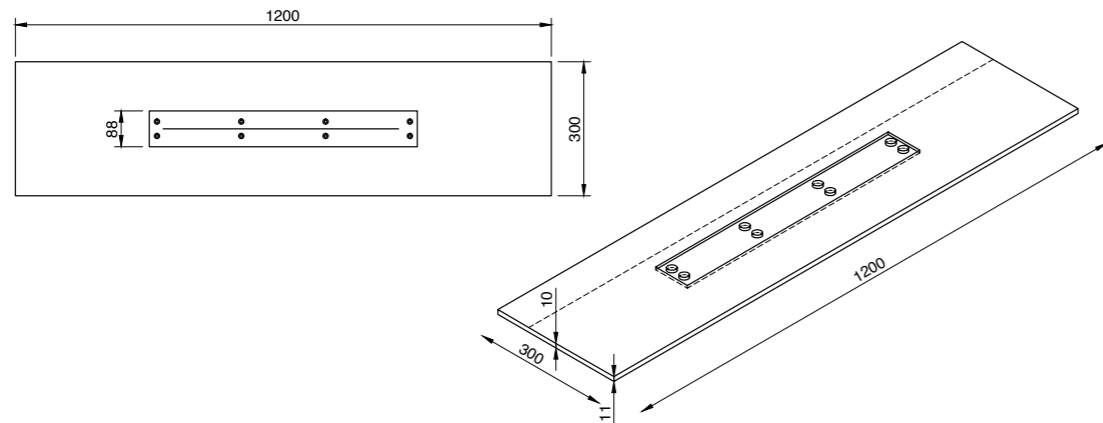

TAPERED BOARD

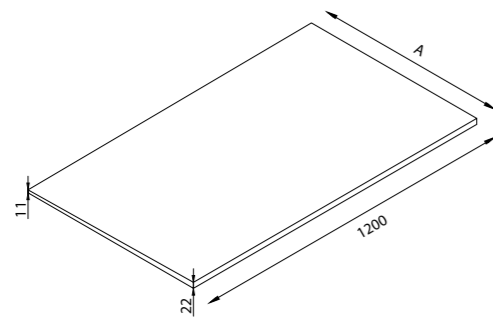

INFIL PANEL

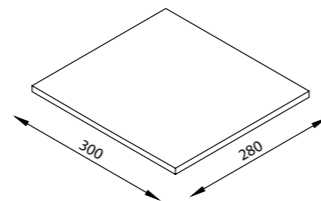

TAPERED BOARDS - PERFORMANCE & COMPOSITION

Density	2.80 - 4.30 kg/m
Thermal Conductivity	0.028 - 0.035 w/mK
Compressive Strength	3kg/cm ² (300kN/m ²)
Water absorption (immersion)	Din 53428 0.2% by vol
Water absorption (capillary)	Din 53428 Nil
Coefficient of linear expansion	ASMT D-696 14.5 x 10.5
Flammability	Class 0, B1/B2 (depending on the conditions of application)

Full technical data sheet available on request from our technical department.

2.1 MODULAR WET-FLOOR

FLOOR DRAIN

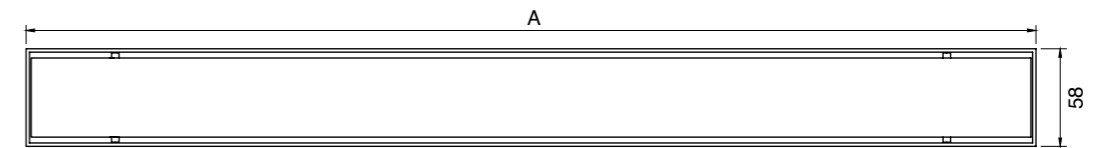

WALL DRAIN

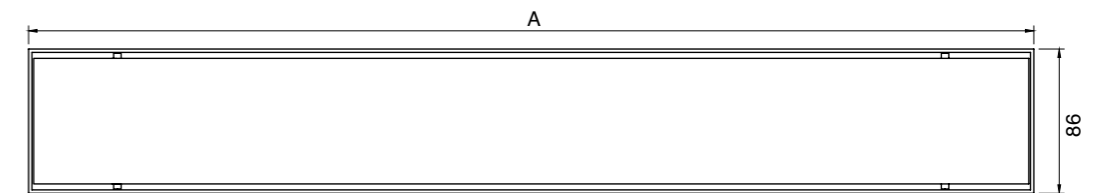

TRAP

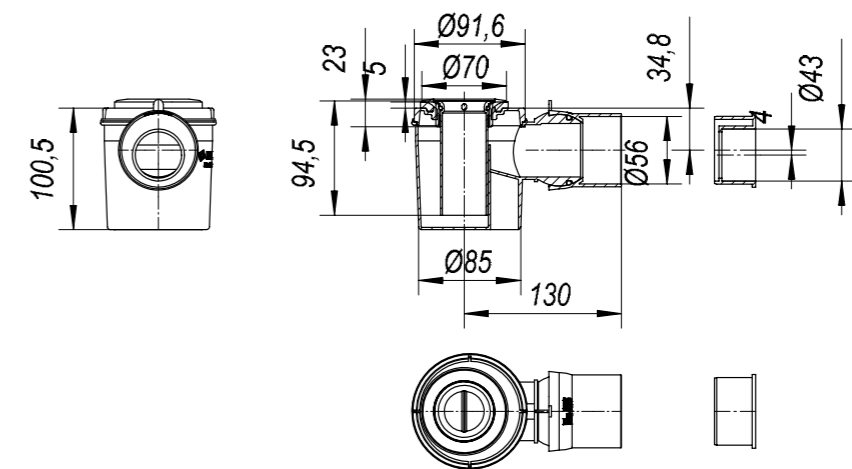

3.1 LINEAR WET-DEC

FINISHED PRODUCT



The Linear Wet-Dec pre-formed shower base has been developed specifically to allow the installation of a wetroom on a timber floor.

Available in a range of sizes, the dec has a built-in gradient ensuring that water from the shower is directed towards the integral linear drain, giving a sleek and stylish finish.

The key feature of the Linear Wet-Dec is its two way fall which allows the tiling to be laid without diagonal cuts, therefore making it ideal for use with large format tiles.

The integrated linear drain is available with one, two or three traps and a choice of stylish grill finishes.

KEY FEATURES

- Designed for timber floors
- Two way fall - suited to large format tiles
- 9 pre-formed sizes
- Trimmable
- Lifetime Guarantee
- Stylish linear drain
- Variable waste position
- Flow rate up to 68 L/min
- Height adjustable grill

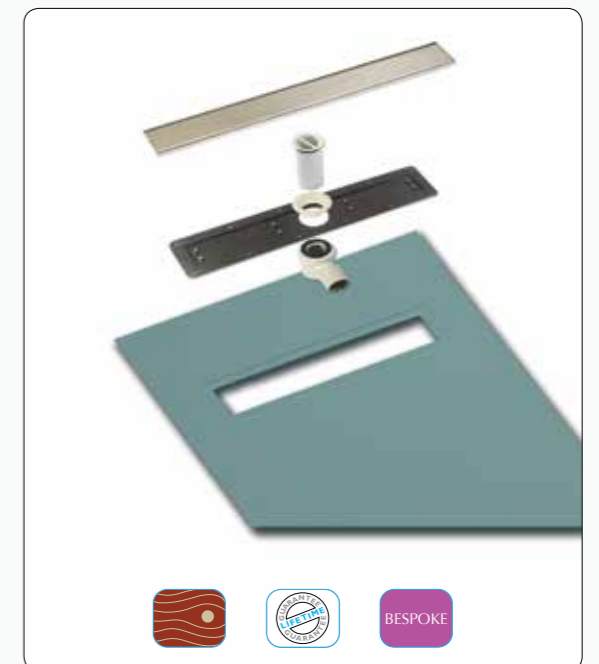

3.1 LINEAR WET-DEC

DEC

The Linear Wet-Dec is manufactured using a high-density XPS foam with a mineral coating on both sides, making them both lightweight and easy to handle, whilst maintaining good thermal properties and compressive strength.

The Dec has a pre-formed 12mm fall, providing a consistent two way gradient every time.

The clever design allows for far higher flow rates than a more traditional four-way fall Dec whilst the linear drain makes it ideal for the installation of large format tiles

Each Linear Wet-Dec is supplied with a stainless steel trim for detailing the difference in tile heights where the dec meets the remainder of the bathroom floor - see image for details.

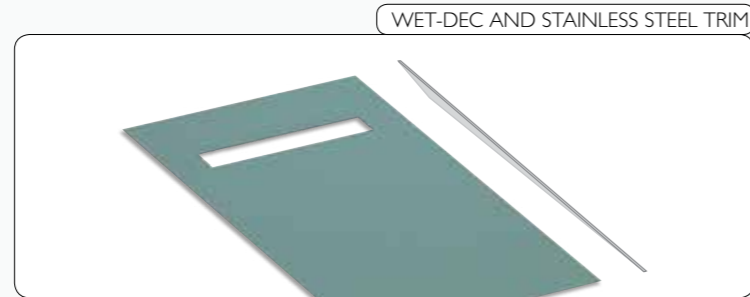

- Designed for timber floors
- Two way fall - suited to large format tiles
- Easily trimmed
- Lifetime guarantee
- Variable trap position
- 22mm Depth

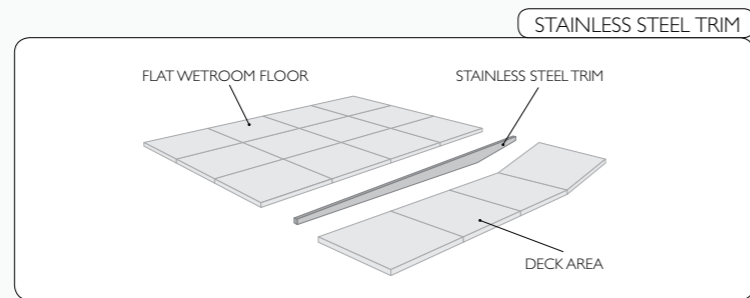

DEC SIZES

The Linear Wet-Dec is available in 9 sizes:

- | A | B | Configuration |
|--------|--------|---------------|
| 900mm | 900mm | End drain |
| 1200mm | 900mm | Centre drain |
| 1200mm | 900mm | End drain |
| 1200mm | 1000mm | End drain |
| 1500mm | 900mm | End drain |
| 1500mm | 1000mm | End drain |
| 1800mm | 900mm | End drain |
| 1800mm | 900mm | Centre drain |
| 1000mm | 1000mm | End drain |

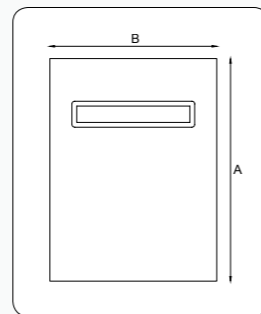

3.1 LINEAR WET-DEC

TRAP

The trap has an adjustable ball joint and comes with removable dip-tube.

For ease of installation, it can be fitted anywhere within the central section of the trough, making it simple to avoid joists and other such obstructions.



- Multi-directional outlet
- Variable position
- 50mm Water seal
- 50mm Outlet, supplied with 50mm-42mm reducer
- BS1455/1566
- Easy to maintain

NO. OF TRAPS

A single trapped Linear Wet-Dec has a flow rate of up to 27 L/min*. The trap can be fitted anywhere within the trough.

When a higher flow rate is required a double trap version is available, allowing up to 50 L/min*.

For higher flow rates a triple trapped drain is also available.

* See flow rate chart for full details.

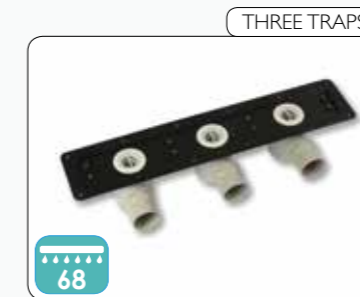

FLOW RATES

No. of traps	No. of wastes		
	1	2	3
1	25 L/min	n/a	n/a
2	41 L/min	41 L/min	n/a
3	41 L/min	41 L/min	60 L/min
1	27 L/min	n/a	n/a
2	50 L/min	50 L/min	n/a
3	50 L/min	61 L/min	68 L/min

Stone / Solid-infill
Slotted / Square Holes

3.1 LINEAR WET-DEC

GRILL FINISH

The grill is available in various different finishes.

All are manufactured in 316 marine grade stainless steel, ensuring a stunning high quality finish.

Type A - Solid Grill is supplied as standard unless otherwise specified.

Type A - Solid Grill:
Grained stainless steel with a 3mm gap around the grill for a sleek stylish finish.

Type B - Oblong Slots:
Three rows of oblong slots in a grained stainless steel finish.

Type C - Square Holes:
Three rows of squares in a grained stainless steel finish.

Type S - Stone-infill:
Allows a section of tile to be inserted to provide a sleek continuous look. Suitable for 10-12mm stone / porcelain tiles. Bespoke depths available to order.



HEIGHT ADJUSTMENT

The grill is height adjustable in 1mm increments to suit tile thicknesses of 6mm to 20mm.

Additional spacers are available upon request for tiles thicker than 20mm.

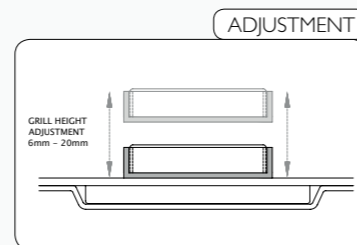

HOW TO SPECIFY

To specify your Linear Wet-Dec, first select the required number of traps (depending on the required flow rate), followed by the grill length and finally the grill finish.

Example: A single trap, 1800mm x 900mm, Linear Wet-Dec with solid grill would have the code: LWD 105/Type A

Membrane

It is essential that the floor is waterproofed or 'tanked' using one of the membranes in the 'product details' on page 6.

For timber floors we would recommend the Tilesafe membrane is applied to the entire wetroom floor.

FWM should then be applied to the walls of the shower area and overlapped onto the Tilesafe Reinforcing Tape.

3.1 LINEAR WET-DEC



PRODUCT DETAILS

IMAGE	DESCRIPTION	DEC SIZE	DRAIN POSITION	PRODUCT REF
	Single trap Linear Wet-Dec, supplied with solid grill as standard ¹	900mm x 900mm	End	LWD 101
		1200mm x 900mm	Centre	LWD 102
		1200mm x 900mm	End	LWD 103
		1200mm x 1000mm	End	LWD 113
	Maximum flow rate 27 L/min	1500mm x 900mm	End	LWD 104
		1500mm x 1000mm	End	LWD 114
		1800mm x 900mm	End	LWD 105
	1800mm x 900mm	Centre	LWD 106	
	1000mm x 1000mm	End	LWD 107	
	Double trap Linear Wet-Dec, supplied with solid grill as standard ¹	900mm x 900mm	End	LWD 201
		1200mm x 900mm	Centre	LWD 202
		1200mm x 900mm	End	LWD 203
		1200mm x 1000mm	End	LWD 213
	Maximum flow rate 50 L/min	1500mm x 900mm	End	LWD 204
		1500mm x 1000mm	End	LWD 214
		1800mm x 900mm	End	LWD 205
	1800mm x 900mm	Centre	LWD 206	
	1000mm x 1000mm	End	LWD 207	
	Triple trap Linear Wet-Dec, supplied with solid grill as standard ¹	900mm x 900mm	End	LWD 301
		1200mm x 900mm	Centre	LWD 302
		1200mm x 900mm	End	LWD 303
		1200mm x 1000mm	End	LWD 313
	Maximum flow rate 68 L/min	1500mm x 900mm	End	LWD 304
		1500mm x 1000mm	End	LWD 314
		1800mm x 900mm	End	LWD 305
	1800mm x 900mm	Centre	LWD 306	
	1000mm x 1000mm	End	LWD 307	

¹ Type A – Solid Grill is supplied as standard. For alternative grill finishes please see page 4.

3.1 LINEAR WET-DEC

WATERPROOFING

IMAGE	DESCRIPTION	PRODUCT REF	
	<p>RIW Tilesafe – A superior waterproof membrane designed for use in wetrooms, prior to the application of ceramic tiles and natural stone².</p> <ul style="list-style-type: none"> • Self-adhesive • Quick and easy to install • Lifetime Guarantee • De-coupling properties 	5m ²	TSK-5
	<p>RIW FWM – A liquid membrane designed for waterproofing walls, fully compatible with Tilesafe and Screedsafe².</p>	8kg	FWM-8

² For full technical details please refer to section 4

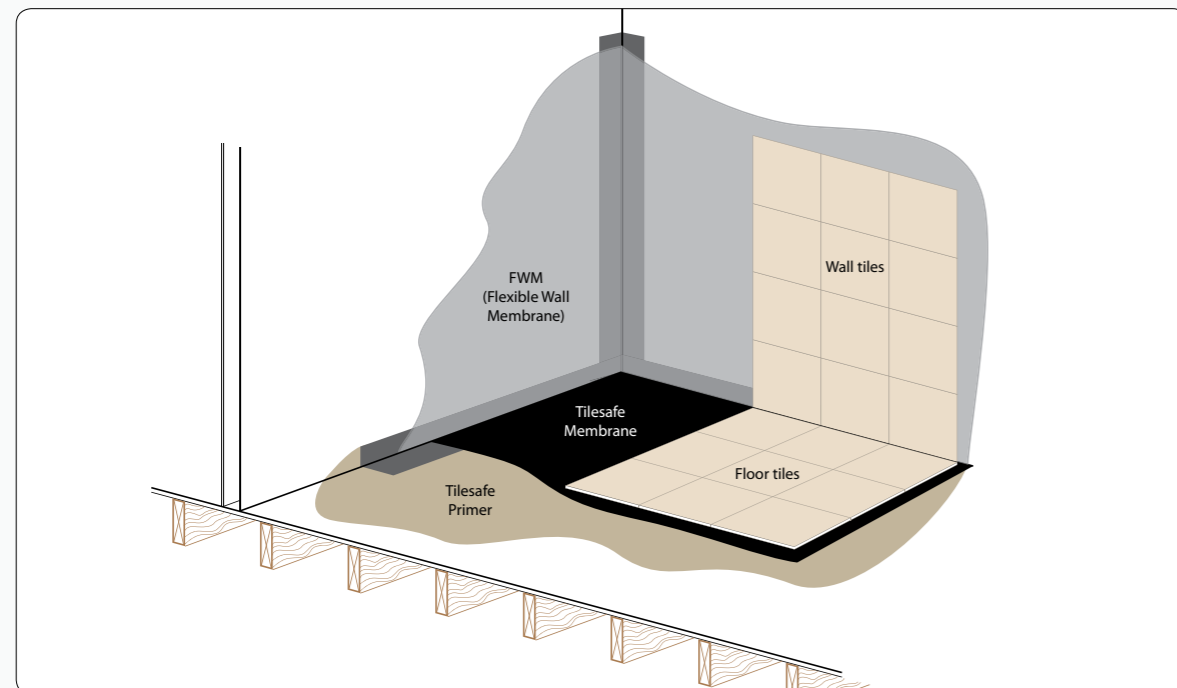

3.1 LINEAR WET-DEC

IN DETAIL

FLOOR BUILD UP

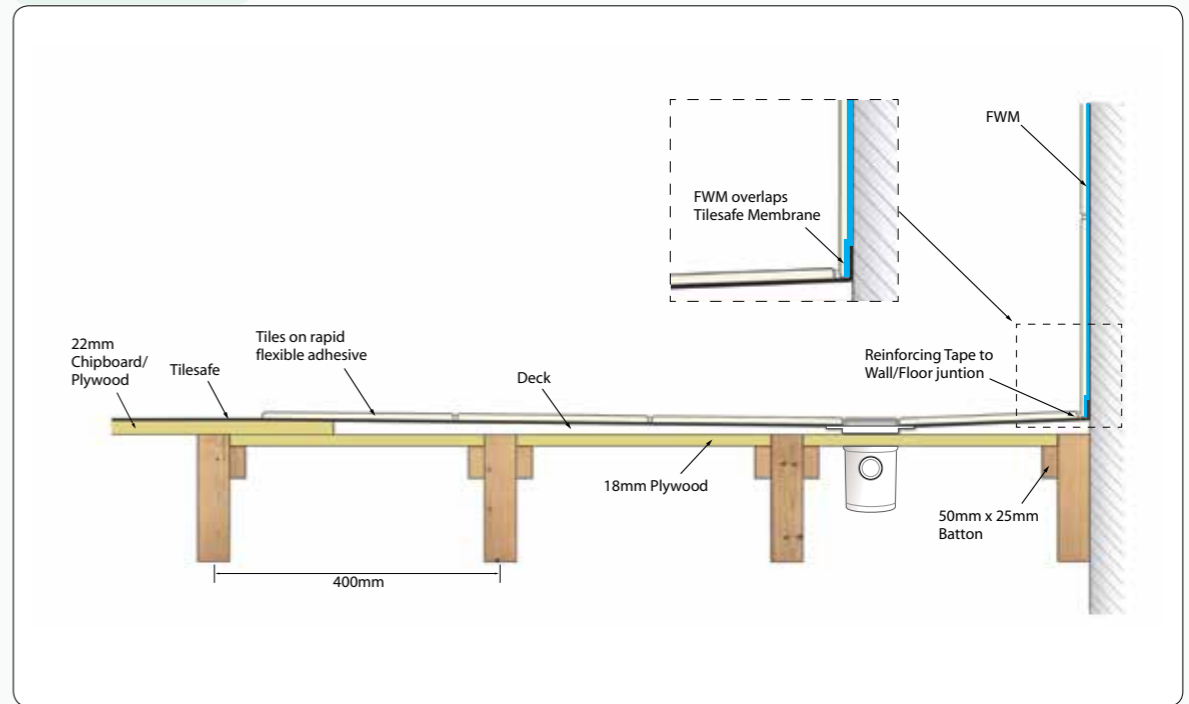

TRAP

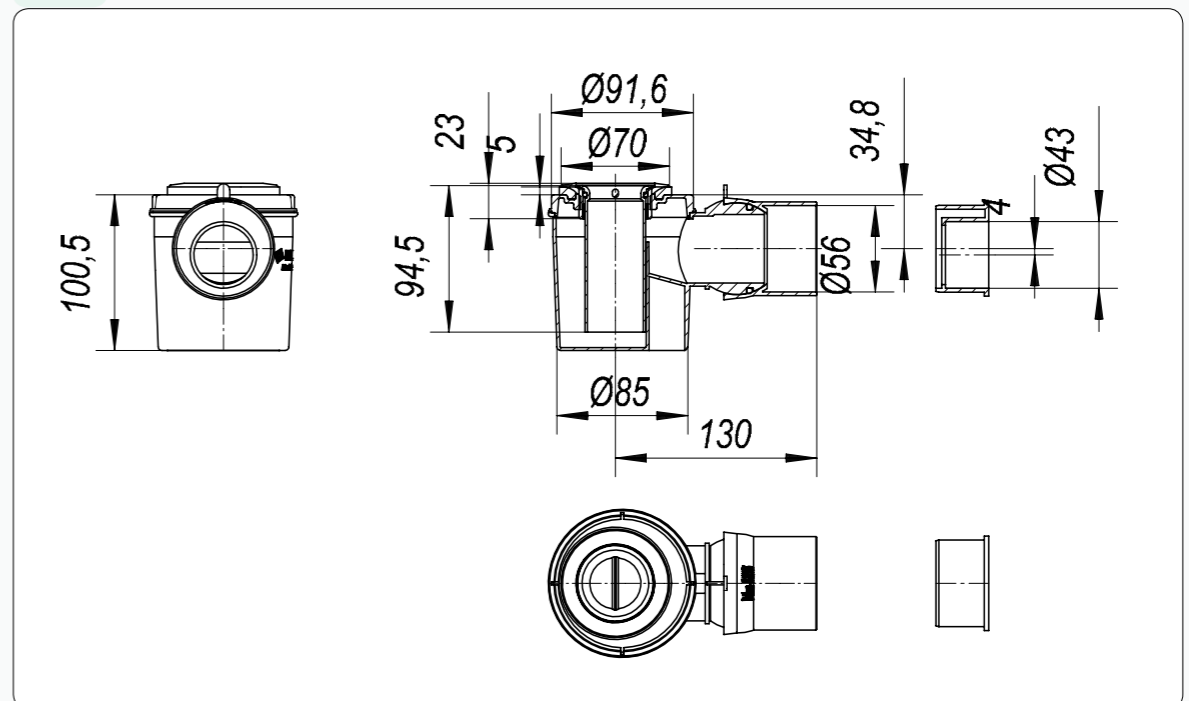

3.1 LINEAR WET-DEC

LWD 101 - 900 x 900mm

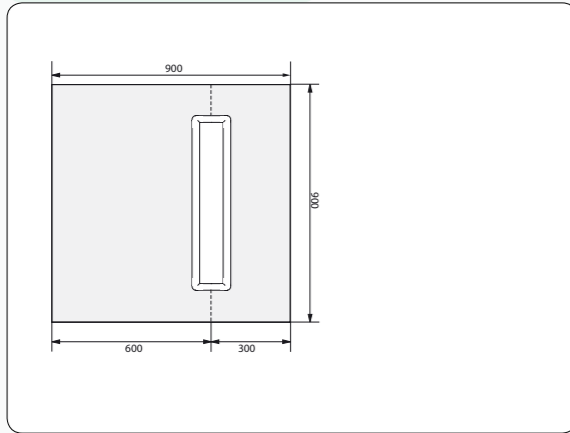

LWD 102 - 1200 x 900mm

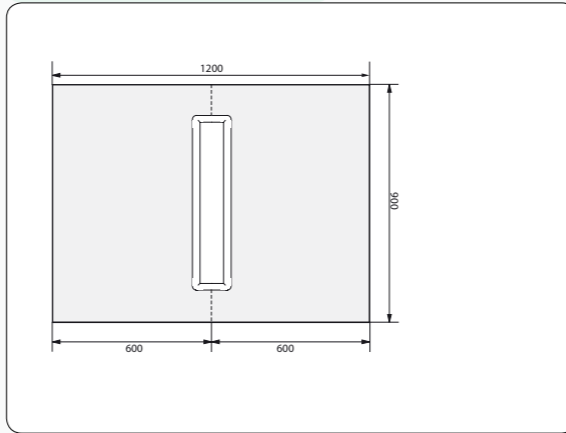

LWD 103 - 1200 x 900mm

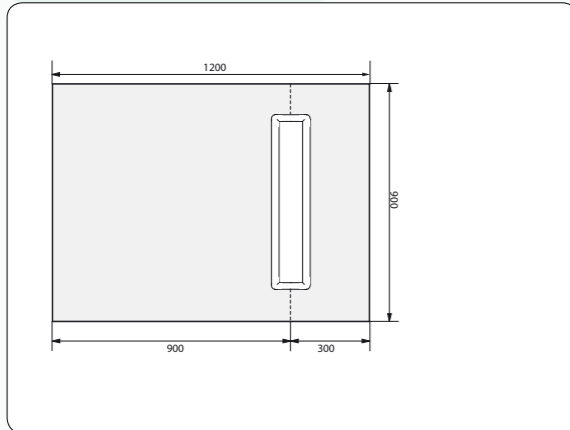

LWD 113 - 1200 x 1000mm

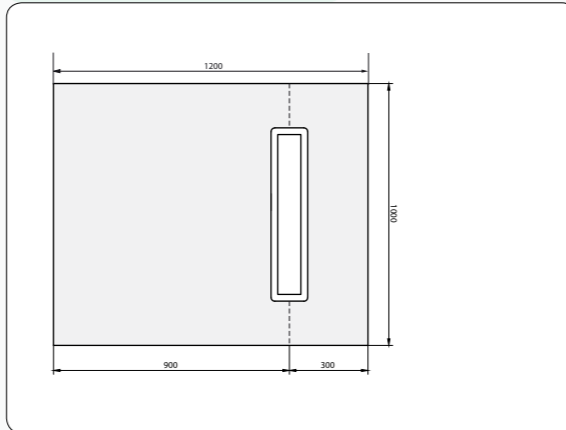

LWD 104 - 1500 x 900mm

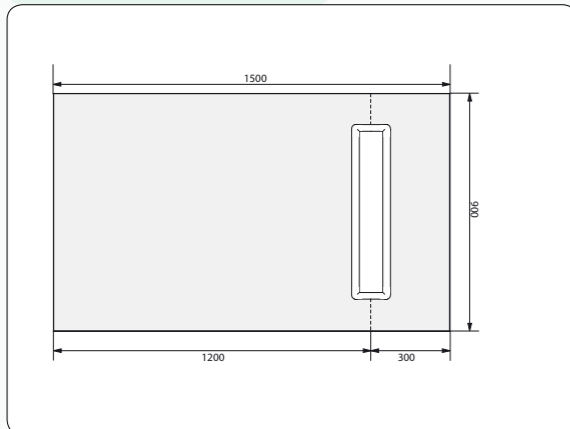

LWD 114 - 1500 x 1000mm

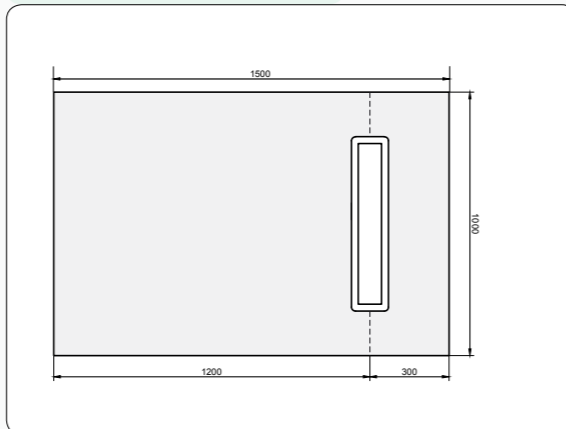

3.1 LINEAR WET-DEC

LWD 105 - 1800 x 900mm

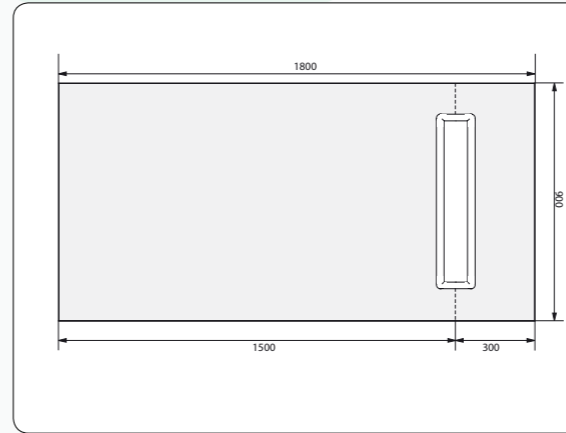

LWD 106 - 1800 x 900mm

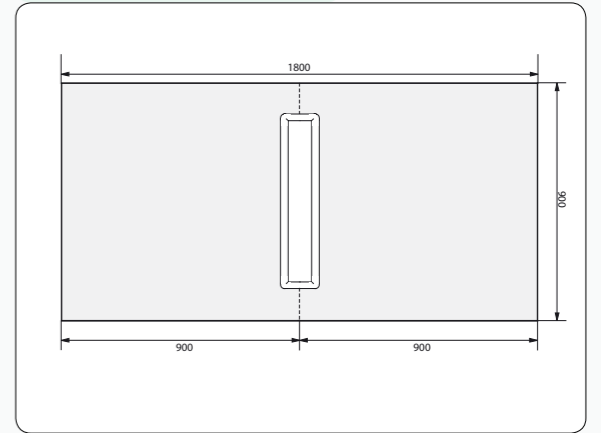

LWD 107 - 1000 x 1000mm

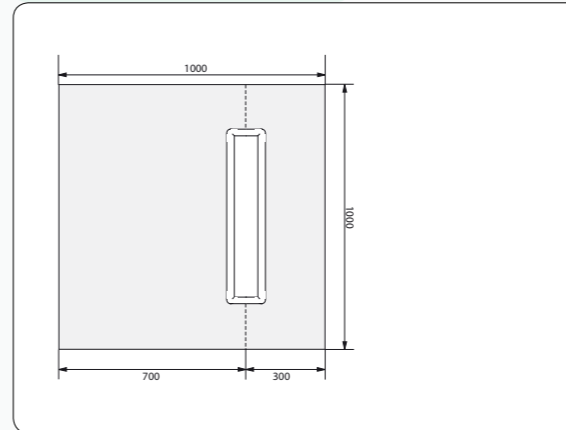

3.1 LINEAR WET-DEC

3.1 LINEAR WET-DEC

3.2 WET-DEC

FINISHED PRODUCT



The Wet-Dec is a pre-formed shower base developed specifically to allow the installation of a wetroom onto a timber floor.

Available in a range of sizes, the Wet-Dec has a built-in gradient ensuring that water from the shower is directed towards the drain outlet.

The Wet-Dec has a built-in four-way fall which provides a consistent gradient, making it ideal for use with mosaic tiles.

Each Wet-Dec is supplied with our height adjustable shower drain which is available in a choice of stylish finishes.

KEY FEATURES

- Designed for timber floors
- Four-way fall - suited to mosaic tiles
- 8 pre-formed sizes
- Trimmable
- Lifetime Guarantee
- Flow rate up to 27 L/min
- Height adjustable grill
- Flexible drain outlet



3.2 WET-DEC

DEC

The Wet-Dec is manufactured using a high-density XPS foam with a mineral coating on both sides, making them both lightweight and easy to handle, whilst maintaining good thermal properties and compressive strength.

The four-way fall provides a consistent gradient of approximately 12mm to the drain, making it ideal for the installation of mosaic tiles.

WET-DEC COMPONENTS

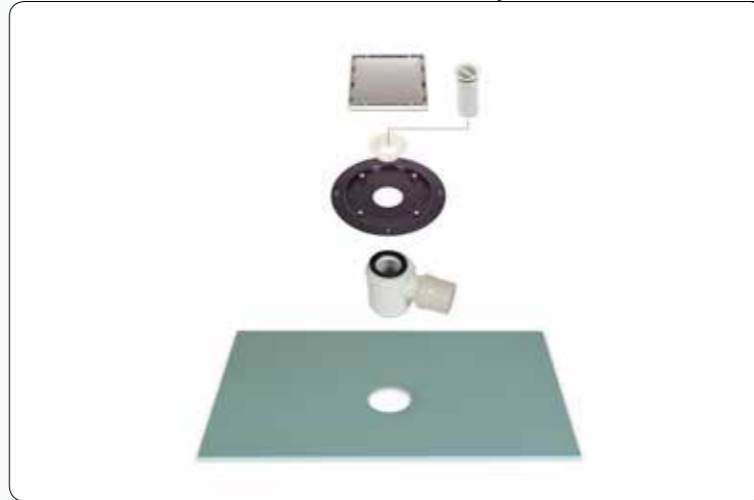

- Designed for timber floors
- Four-way fall - suited to mosaic tiles
- 8 pre-formed sizes
- Can be trimmed by up to 50mm
- Lifetime guarantee
- 22mm Depth

DEC SIZES

The Wet-Dec is available in 8 sizes:

- | A | B |
|-------------------|---|
| • 900mm × 900mm | |
| • 1000mm × 1000mm | |
| • 1200mm × 1200mm | |
| • 1200mm × 900mm | |
| • 1200mm × 1000mm | |
| • 1500mm × 900mm | |
| • 1500mm × 1000mm | |
| • 1800mm × 900mm | |

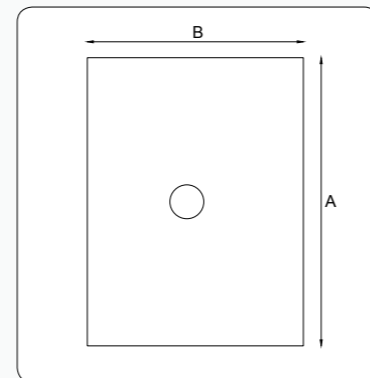

3.2 WET-DEC

TRAP

The trap has an adjustable ball joint for ease of installation and comes with removable dip-tube.

The trap is located within the base component which comes un-drilled allowing for extra flexibility.

- Multi-directional outlet
- 50mm Water seal
- 50mm Outlet, supplied with 50mm-42mm reducer
- BS1455/1566
- Easy to maintain
- Flow rate up to 27 L/min

TRAP WITH GRILL AND DRAIN



GRILL FINISH

The grill is available in various different finishes. All are manufactured in 316 marine grade stainless steel, ensuring a stunning high quality finish.

Type A Solid Grill is supplied as standard unless otherwise specified.

Type A - Solid Grill: Grained stainless steel with a 5mm gap around the grill for a sleek stylish finish.

Type B - Oblong slots: Rows of oblong slots in a grained stainless steel finish.

Type S - Stone - Infill Grill: Allows a section of tile to be inserted to provide a sleek continuous look. Suitable for 10-12mm stone/porcelain tiles. Bespoke depths available to order.

TYPE A



TYPE B



TYPE S



HEIGHT ADJUSTMENT

The grill is height adjustable in 1mm increments to suit tile thicknesses of 6mm to 20mm.

Additional spacers are available upon request for tiles thicker than 20mm.

ADJUSTMENT

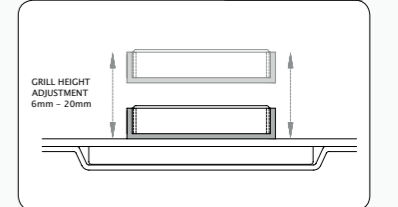

3.2 WET-DEC

WATERPROOFING

IMAGE	DESCRIPTION	DEC SIZE	PRODUCT REF
	Wet-Dec, Maximum flow rate 27 L/min.	900mm x 900mm	WD10
		1000mm x 1000mm	WD11
		1200mm x 1200mm	WD12
		1200mm x 900mm	WD20
		1200mm x 1000mm	WD21
		1500mm x 900mm	WD22
		1500mm x 1000mm	WD23
		1800mm x 900mm	WD24
	RIW Tilesafe – A superior waterproof membrane designed for use in wetrooms, prior to the application of ceramic tiles and natural stone ² . <ul style="list-style-type: none"> • Self-adhesive • Quick and easy to install • Lifetime Guarantee • De-coupling and acoustic properties 	5m ²	TSK-5
		10m ²	TSK-10
	RIW FWM – A liquid membrane designed for waterproofing walls, fully compatible with Tilesafe.	8kg	FWM-8

² For full technical details please refer to Section 4

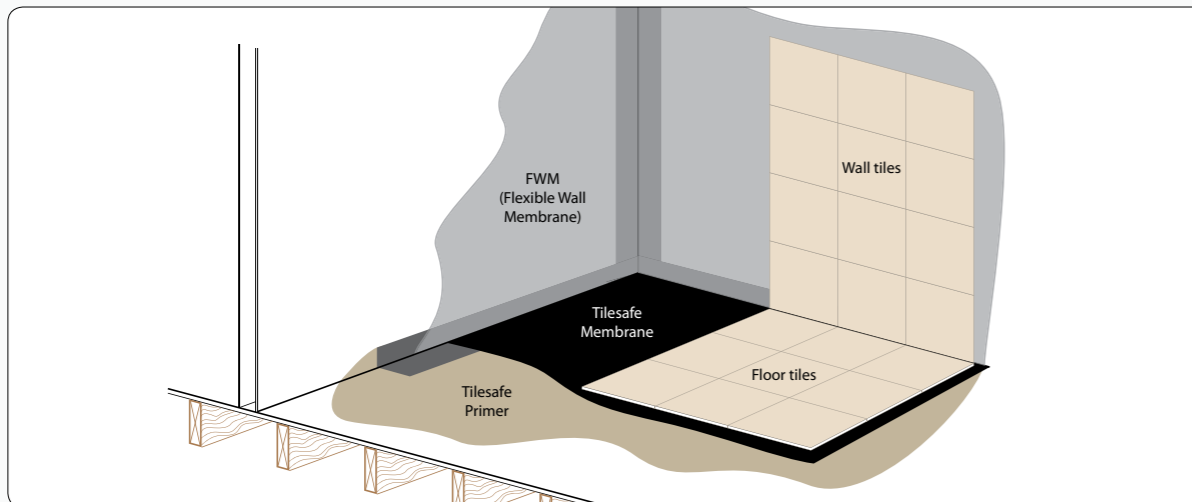

3.2 WET-DEC

HOW TO SPECIFY

To specify your Wet-Dec, first select the required size of shower area, followed by the grill height and finally the grill finish.

Example: 1200mm x 900mm Wet-Dec with Stone-Infill grill would be code: **WD20/Type S**

Membrane

It is essential that the floor is waterproofed or 'tanked' using one of the membranes in the 'product details' on page 4.

For timber floors we would recommend the Tilesafe membrane is applied to the entire wetroom floor.

FWM should then be applied to the walls of the shower area and overlapped onto the Tilesafe Reinforcing Tape.

IN DETAIL

CROSS SECTION SHOWING WET-DEC AND OVERLAPPING FWM

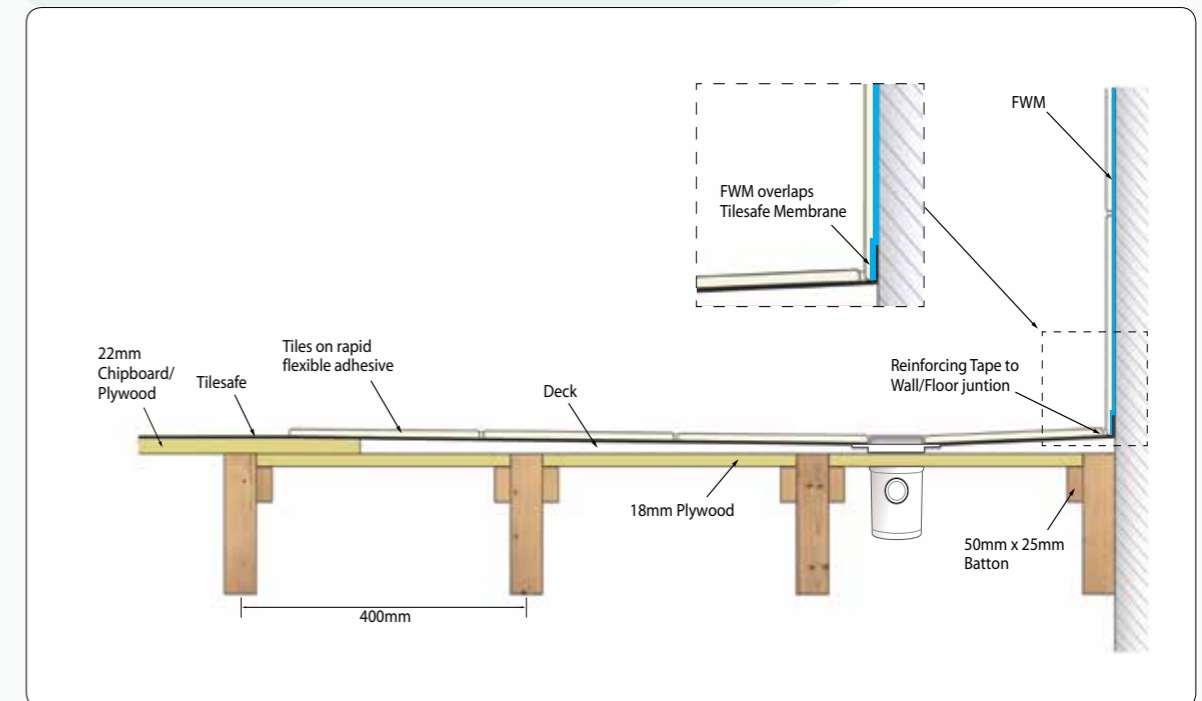

3.2 WET-DEC

TRAP

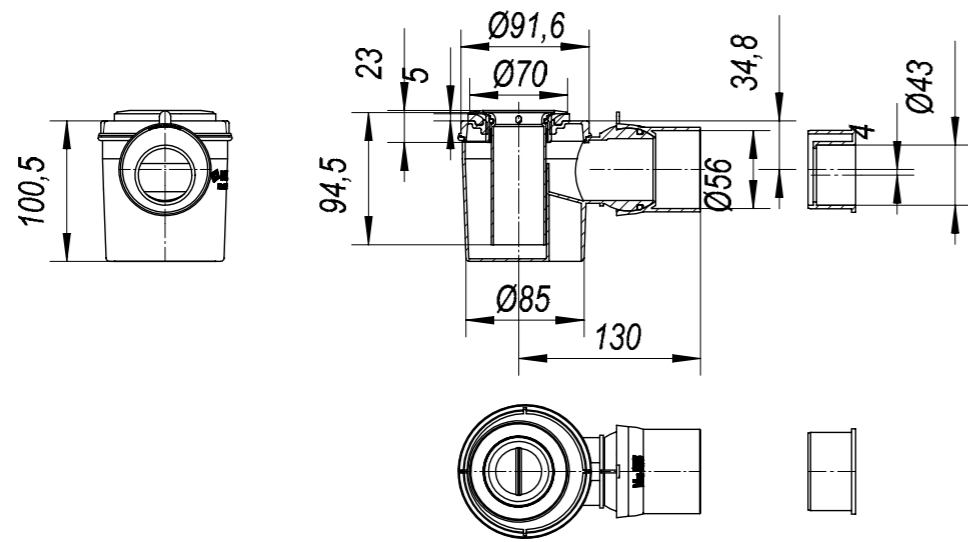

WD10 - 900 x 900mm

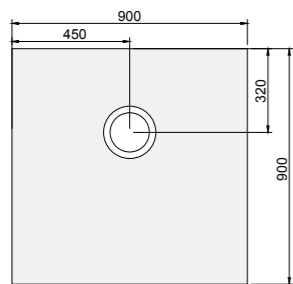

WD11 - 1000 x 1000mm

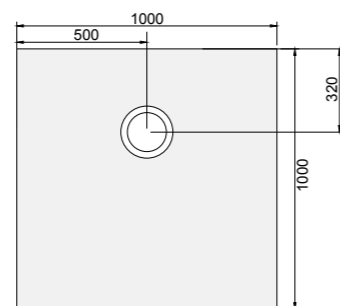

3.2 WET-DEC

WD12 - 1200 x 1200mm

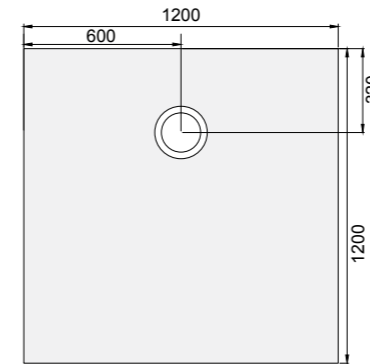

WD20 - 1200 X 900mm

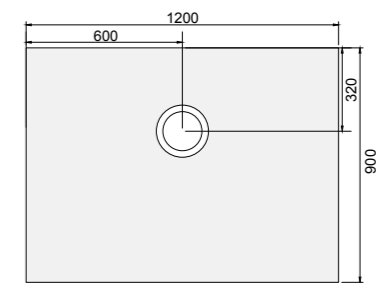

WD21 - 1200 x 1000mm

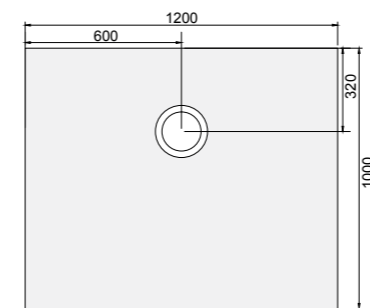

WD22 - 1500 X 900mm

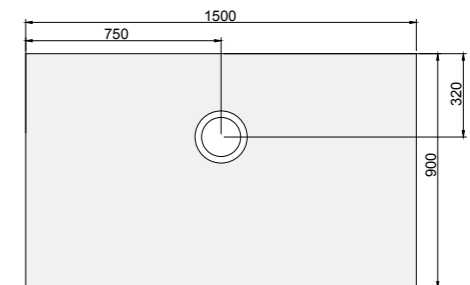

WD23 - 1500 X 1000mm

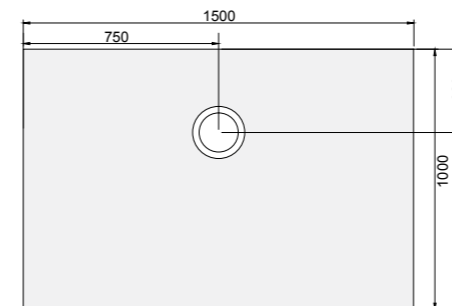

WD24 - 1800 x 900mm

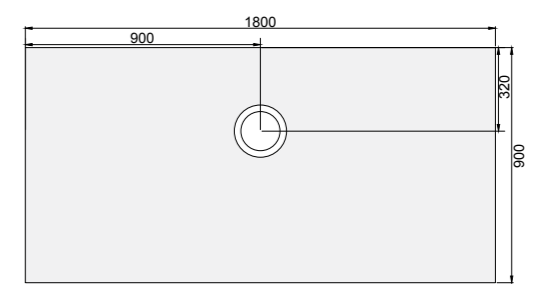

4.1 RIW TILES SAFE

PRODUCT DETAIL

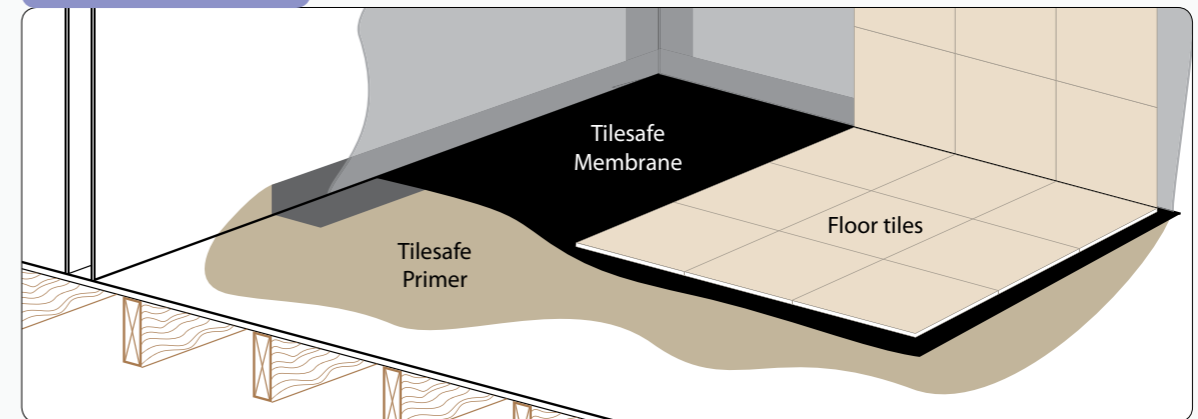

RIW Tilesafe is a self-adhesive waterproof membrane designed for use prior to the application of ceramic tiles and natural stone onto timber and solid floors in wetrooms and other critical areas.

Tilesafe comprises a self-adhesive cold applied waterproof membrane which consists of a thick rubberised waterproof layer incorporating a woven glass fibre mesh on one side. Tilesafe is quick and easy to apply, providing a consistent waterproof layer that is guaranteed not to leak.

Tilesafe will also act as an effective de-coupling membrane by uncoupling the floor tiles and accommodating movement in the substrate.

Tilesafe acts as an acoustic barrier and will improve the sound impact insulation value (ΔL_w) of a wet room typical floor assembly by 11 dB.

The tests were conducted in accordance with BS EN ISO 140-8 with the results (ΔL) rated in accordance with BS EN ISO 717-2.

KEY FEATURES

- Lifetime guarantee
- Suitable for timber and solid floors
- Self-adhesive - quick and easy to apply
- Ready to tile immediately
- Ideal for fast track construction
- Supplied as a kit
- De-coupling properties
- Acoustic properties
- Factory controlled thickness



4.1 RIW TILES SAFE

KIT CONTENTS

Tilesafe Membrane

A self-adhesive waterproof membrane consisting of a 2mm thick rubberised layer, incorporating a woven glass fibre mesh on one side.
Width 1 Metre.

Tilesafe Reinforcing Tape

A 1mm thick self-adhesive tape for reinforcing all wall and floor junctions, butt joints and other detail work in the membrane.
Width 150mm.

Tilesafe Primer

A quick drying acrylic primer for use prior to the application of Tilesafe membrane and Reinforcing Tape.

Tilesafe Jointing Compound

A high quality polymer based sealant for use at all butt joints, pipe entries, wall and floor junctions.

Tilesafe Putty

A non-setting self-supporting putty for filling small gaps or voids around pipe entries etc.

TILES SAFE KIT



PRE-FORMED CORNERS

Tilesafe Pre-Formed Corners
Designed to simplify the installation of Tilesafe.

Manufactured from tough but flexible polyethylene, the corner unit is placed into a corner prior to the installation of Tilesafe Reinforcing Tape at wall/floor junctions.

PRE-FORMED CORNERS

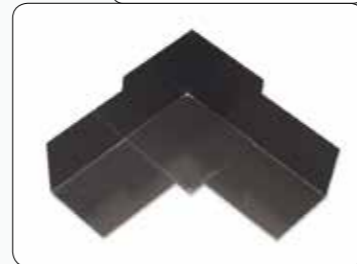

TILES SAFE REINFORCING TAPE

Tilesafe Reinforcing Tape
150mm wide self-adhesive waterproofing tape for sealing critical detail such as wall junctions, soap recesses, pipe boxing and other such areas prior to tiling.
Roll length 7.5m.

REINFORCING TAPE



4.1 RIW TILES SAFE

PRODUCT DETAILS

IMAGE	DESCRIPTION	PRODUCT REF
	5m² Tilesafe kit Kit contains – 5m x 1m roll of Membrane, 10m Reinforcing Tape, 500ml Primer, 310ml Jointing compound, 500g Putty	TSK-5
	10m² Tilesafe kit Kit contains – 10m x 1m roll of Membrane, 15m Reinforcing Tape, 1Ltr Primer, 310ml Jointing compound, 500g Putty	TSK-10
	Pack of 2 pre-formed corners	TSC-2
	7.5m Roll of Reinforcing Tape	TSR-7.5

For wall membrane use **RIW FWM**. Please refer to section 4.2 for full details.

For timber floors we recommend that the Tilesafe membrane is applied to the entire wetroom floor.

For solid floors we recommend that the Tilesafe membrane is applied to the shower area plus an additional one metre in either direction.

FWM should then be applied to the walls of the shower area and overlapped onto the Tilesafe Reinforcing Tape.

Care should be taken to ensure the temperature is at least 10°C. Conditioning of the membrane in a warm area prior to use will enhance its adhesion properties during application.

4.1 RIW TILES SAFE

IN DETAIL

Tilesafe is a unique, pre-formed flexible self-adhesive waterproof membrane that will accommodate differential movement between building elements, which is the principal weakness in alternative systems.

It is, therefore, ideal for use on modular and 'lively' substrates, such as timber, masonry, concrete, plasterboards, gypsum and existing ceramic or natural stones. Once applied Tilesafe is ready to tile immediately.

Tilesafe is cold applied, consisting of a 2mm thick rubberised waterproof layer, incorporating a woven glass fibre mesh on one side. It has been developed for use prior to the fixing of ceramic tiles and natural stone, applied using a flexible rapid-set tile adhesive, which keys to the mesh. As the adhesive dries it forms a strong permanent bond through the mesh and directly onto the waterproof layer.

Tilesafe will also act as an effective de-coupling membrane, uncoupling the floor tiles from the substrate and assisting in counteracting the tensions that are present from differential movement between the substrate and the tiles.

Similarly, static, dynamic or stress cracks present in the substrate are bridged, therefore reflective cracking through the tile is prevented.

Tilesafe acts as an acoustic barrier and will improve the sound impact insulation value (ΔL_w) of a wet room typical floor assembly by 11dB.

Specification M40 – Stone/Concrete/Quarry/Ceramic Tiling/Mosaic.

TILES SAFE PERFORMANCE & COMPOSITION

Membrane thickness	2mm
Joint Tape thickness	1mm
Adhesion	2N/mm
Water vapour transmission	0.5g/m ² / 24 hours
Tensile strength (ASTM D1000)	12N/mm
Pull off adhesion (ASTM C907)	81N
Shear adhesion	115N

DE-COUPLING PERFORMANCE

RIW Tilesafe acts as an effective de-coupling or 'anti fracture' membrane up to a gap of 2.25mm¹ by assisting in counteracting the tensions that are present from differential movement between the substrate and the tiles.

¹ Data provided by an independent UKAS accredited testing laboratory. Tilesafe was subjected to product validation testing using a calibrated data logger.

ACOUSTIC PERFORMANCE

Tilesafe acts as an acoustic barrier and will improve the sound impact insulation value (ΔL_w) of a wet room typical floor assembly by 11dB. The tests were conducted in accordance with BS EN ISO 140-8 with the results (ΔL) rated in accordance with BS EN ISO 717-2.

The tests were carried-out with a fully installed floor assembly with the 2mm Tilesafe Membrane applied directly to a concrete substrate, with 12mm Travertine Tiles adhered directly to the Tilesafe Membrane.

Full technical data available on request from our technical department.

4.1 RIW TILES SAFE

TILES SAFE MEMBRANE IN TYPICAL WETROOM CONSTRUCTION

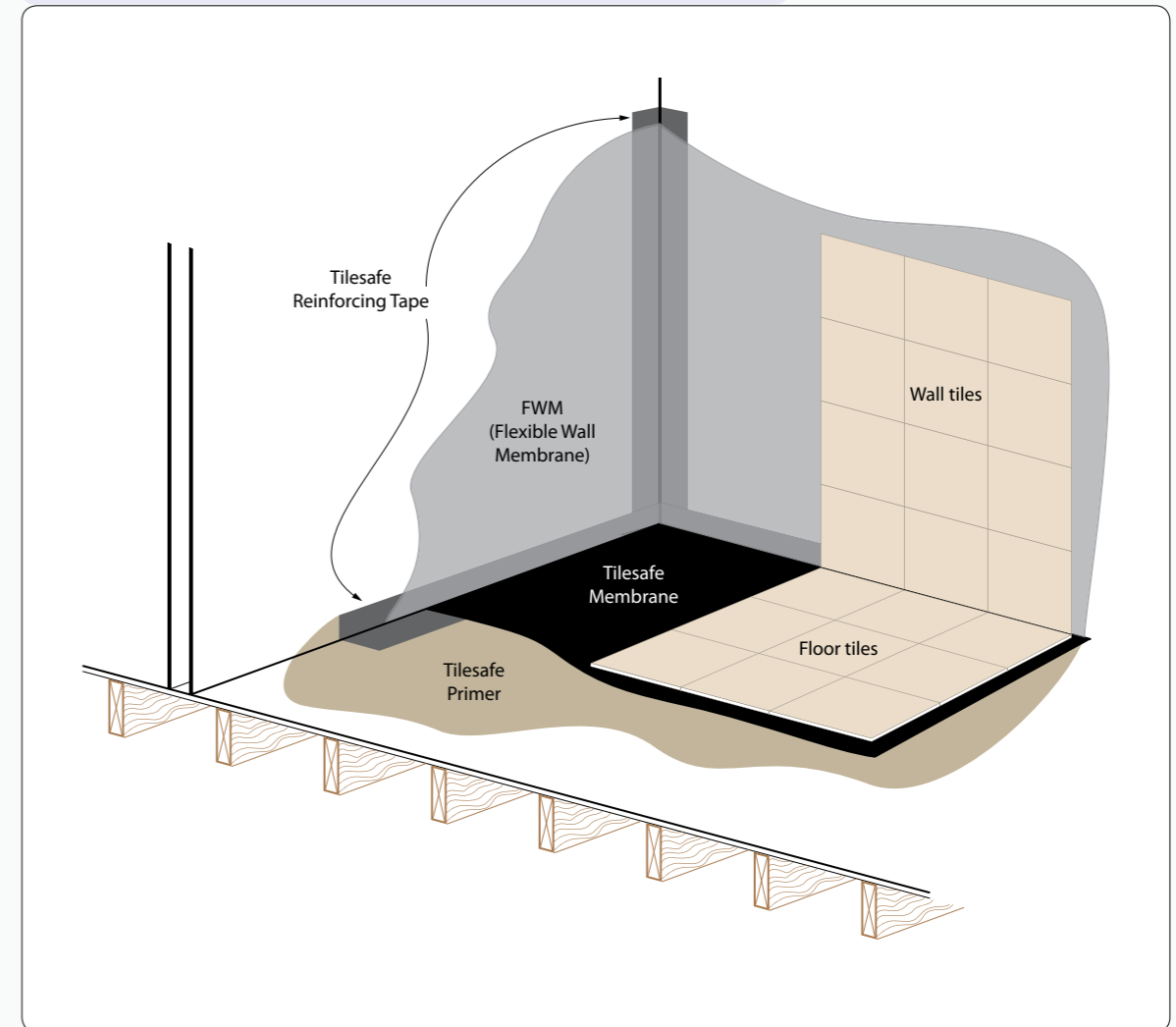

For timber floors we recommend that the Tilesafe membrane is applied to the entire wetroom floor.

For solid floors we recommend that the Tilesafe membrane is applied to the shower area plus an additional one metre in either direction.

FWM should then be applied to the walls of the shower area and overlapped onto the Tilesafe Reinforcing Tape.

4.2 RIW SCREEDSAFE

PRODUCT DETAIL

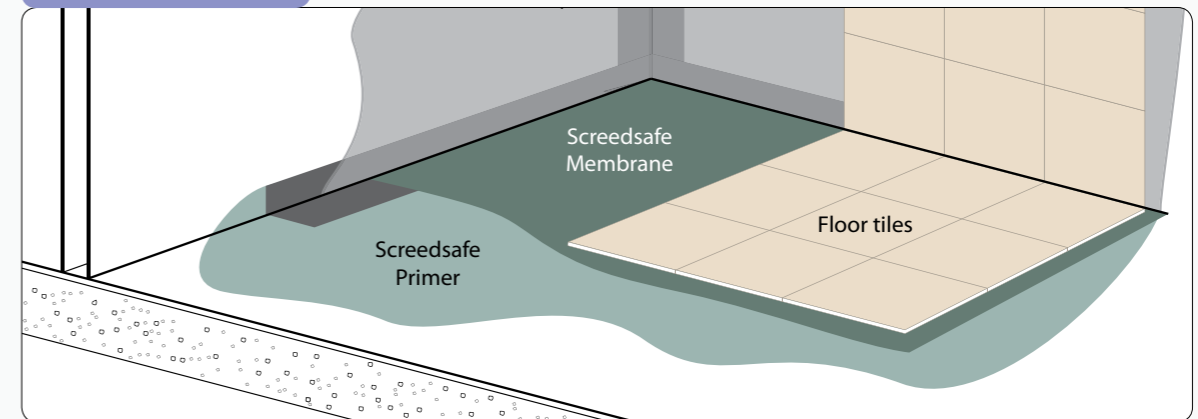

RIW Screedsafe is a self-adhesive waterproof membrane designed for use prior to the application of ceramic tiles, and natural stone onto concrete and screeded in wetrooms and other critical areas.

Screedsafe is quick and easy to apply, providing a consistent waterproof layer that is guaranteed not to leak.

Screedsafe comprises a self-adhesive cold applied waterproof membrane which consists of a 1mm rubberised waterproof layer incorporating a woven fabric on one face.

KEY FEATURES

- Lifetime guarantee
- Suitable for concrete and screeded floors
- Self-adhesive - quick and easy to apply
- Ready to tile immediately
- Ideal for fast track construction
- Supplied as a kit
- Factory controlled thickness



4.2 RIW SCREEDSAFE

KIT CONTENTS

Screedsafe Membrane

A self-adhesive membrane consisting of a 1mm thick rubber modified bitumen waterproof layer, incorporating a woven fabric on one face

Width 1 Metre.

Screedsafe Reinforcing Tape

A 1mm thick self-adhesive tape for reinforcing all wall and floor junctions, butt joints and other detail work in the membrane

Width 150mm.

Screedsafe Primer

A bitumen solution for coating surfaces prior to the application of Screedsafe membrane and Reinforcing Tape.

Screedsafe Jointing Compound

A high quality polymer based sealant for use at all butt joints, pipe entries, wall and floor junctions.

SCREEDSAFE KIT



PRE-FORMED CORNERS

Screedsafe Pre-Formed Corners
Designed to simplify the installation of Screedsafe.

Manufactured from tough but flexible polyethylene, the corner unit is placed into a corner prior to the installation of Screedsafe Reinforcing Tape at wall/floor junctions.

PRE-FORMED CORNERS



SCREEDSAFE REINFORCING TAPE

Screedsafe Reinforcing Tape

150mm wide self-adhesive waterproofing tape for sealing critical detail such as wall junctions, soap recesses, pipe boxing and other such areas prior to tiling.





Roll length 7.5m.

REINFORCING TAPE



4.2 RIW SCREEDSAFE

PRODUCT DETAILS

IMAGE	DESCRIPTION	PRODUCT REF
	5m² Screedsafe kit Kit contains – 5m x 1m roll of Membrane, 7.5m Reinforcing Tape, 500ml Primer, 310ml Jointing compound.	SSK-5
	10m² Screedsafe kit Kit contains – 10m x 1m roll of Membrane, 15m Reinforcing Tape, 1Ltr Primer, 310ml Jointing compound.	SSK-10
	Pack of 2 pre-formed corners	SSC-2
	7.5m Roll of Reinforcing Tape	SSR-7.5

For wall membrane use **RIW FWM**. Please refer to section 4.3 for full details.

For solid floors we recommend that the Screedsafe membrane is applied to the shower area plus an additional one metre in either direction.

FWM should then be applied to the walls of the shower area and overlapped onto the Screedsafe Reinforcing Tape.

Care should be taken to ensure the temperature is at least 10°C. Conditioning of the membrane in a warm area prior to use will enhance its adhesion properties during application.

4.2 RIW SCREEDSAFE

IN DETAIL

Screedsafe is a unique, pre-formed flexible self-adhesive waterproof membrane that will accommodate differential movement between building elements, which is the principal weakness in alternative systems.

It had been designed specifically for use on concrete and screeded floors. Once applied Screedsafe is ready to tile immediately.

Screedsafe is cold applied, consisting of a 1mm thick rubber modified bitumen waterproof layer, incorporating a woven fabric on one face.

It has been developed for use prior to the fixing of ceramic tiles and natural stone, applied using a flexible rapid-set tile adhesive, which keys to the fabric. As the adhesive dries it forms a strong permanent bond.

Screedsafe should only be applied to concrete and screeded floors, under no circumstances should Screedsafe be applied to timber floors. Timber floors should be waterproofed with Tilesafe only.

Specification M40 – Stone/Concrete/Quarry/Ceramic Tiling/Mosaic.

SCREEDSAFE PERFORMANCE & COMPOSITION

Membrane thickness	1mm
Joint Tape thickness	1mm
Adhesion	1.5Nmm
Water vapour transmission	0.5g/m ² / 24 hours
Tensile strength (ASTM D1000)	8.7N/mm
Pull off adhesion (ASTM C907)	84N
Sheer adhesion	59N

Full technical data sheet available on request from our technical department.

4.2 RIW SCREEDSAFE

SCREEDSAFE MEMBRANE IN TYPICAL WETROOM CONSTRUCTION

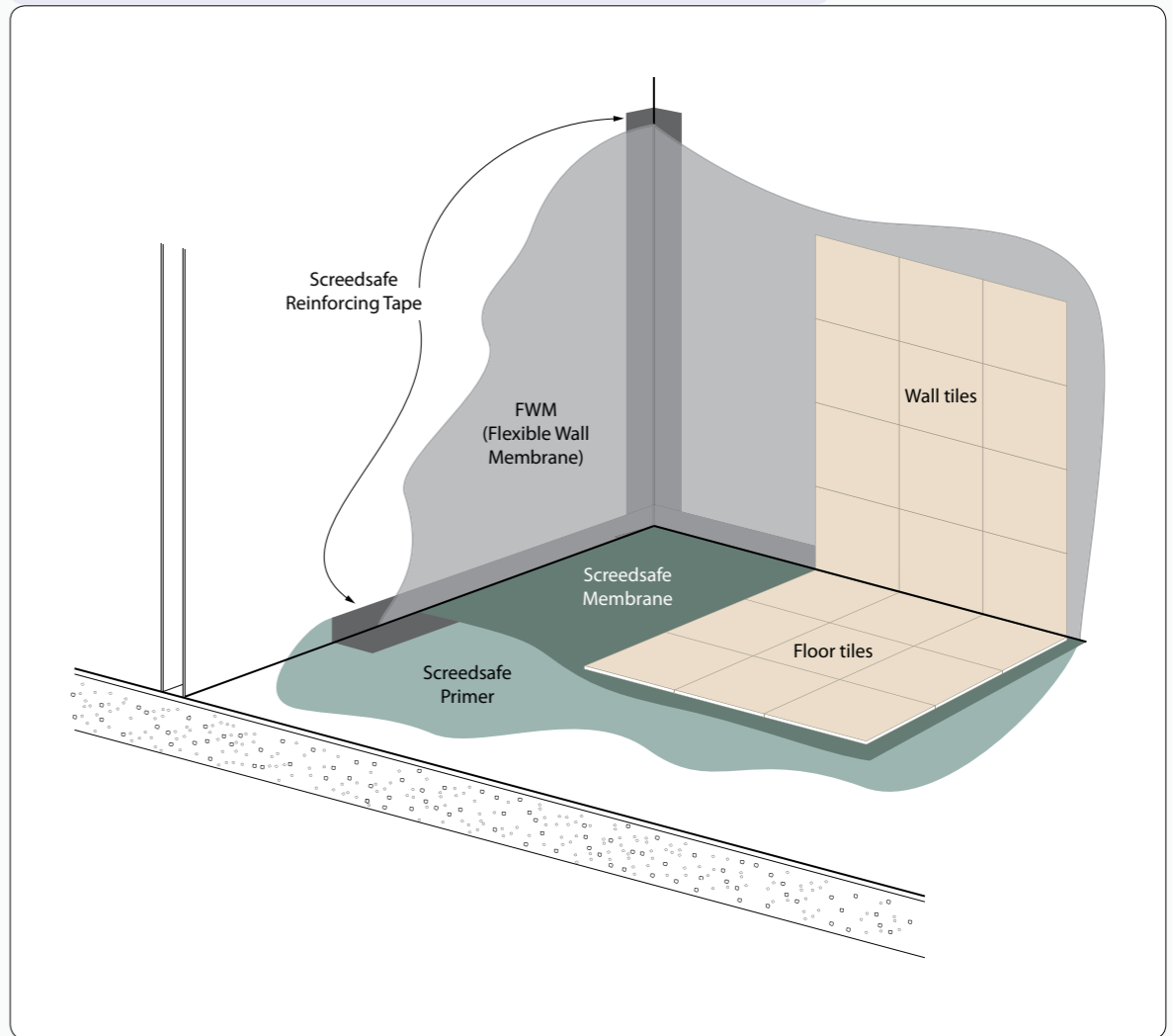

For solid floors we recommend that the Screedsafe membrane is applied to the shower area plus an additional one metre in either direction.

FWM should then be applied to the walls of the shower area and overlapped onto the Screedsafe Reinforcing Tape.

Care should be taken to ensure the temperature is at least 10°C. Conditioning of the membrane in a warm area prior to use will enhance its adhesion properties during application.

4.3 RIW FWM

PRODUCT DETAIL

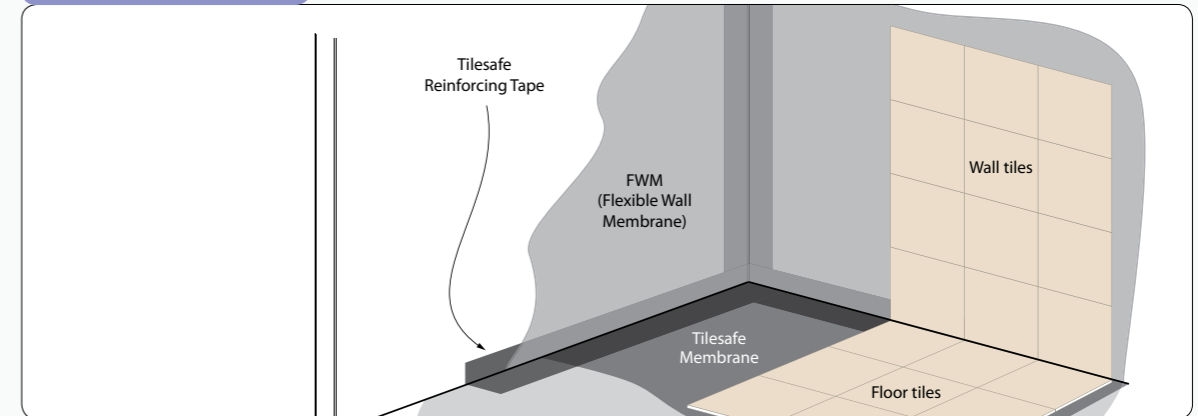

RIW FWM - Flexible Wall Membrane is a flexible coating for waterproofing wall surfaces prior to the application of ceramic tiles and natural stone in wetroom and other critical areas.

KEY FEATURES

- Lifetime guarantee
- Solvent-free
- Quick and easy to apply
- Compatible with Tilesafe and Screedsafe
- Suitable for use on all commonly encountered substrates



PRODUCT DETAILS

IMAGE	DESCRIPTION	PRODUCT REF
	FWM - Flexible Wall Membrane 8kg Tub	FWM-8

4.3 RIW FWM

IN DETAIL

FWM is a ready-to-use, pale blue, solvent-free, soft paste which bonds perfectly to adhesives used for fixing ceramic tiles and natural stone.

It may be used on all commonly encountered wall substrates including plasterboard, gypsum or cementitious render, lightweight cement block and marine plywood.

FWM should be applied using a brush or short pile roller to give a continuous thin layer of product at least 1mm thick.

Junctions between wall and floor and all corners should be reinforced with Reinforcing Tape.

Allow 24 hours before tiling. Should a second coat be necessary, allow to dry for 2 hours between coats.

Specification M40 – Stone/Concrete/Quarry/Ceramic Tiling/Mosaic.

Pack Size: 8kg

Colour: Pale blue

Coverage: 1kg per m² /coat
8m² per 8kg pack – based on 1 coat

FWM PERFORMANCE & COMPOSITION

Paste density	1kg per m ²
Application temperature	Between 5°C and 30°C
Service conditions	-20°C to +50°C
Coat drying time	2 hours touch dry
Before tiling	24 hours*
Contact with water	7 days

*Note: All times refer to site conditions of 20°C. These times will be increased at lower temperatures and reduced at elevated temperatures. The above performance figures are typical values and should not be considered a product specification.

Full technical data sheet available on request from our technical department 0844 327 6002.

4.3 RIW FWM

FWM IN TYPICAL WETROOM CONSTRUCTION

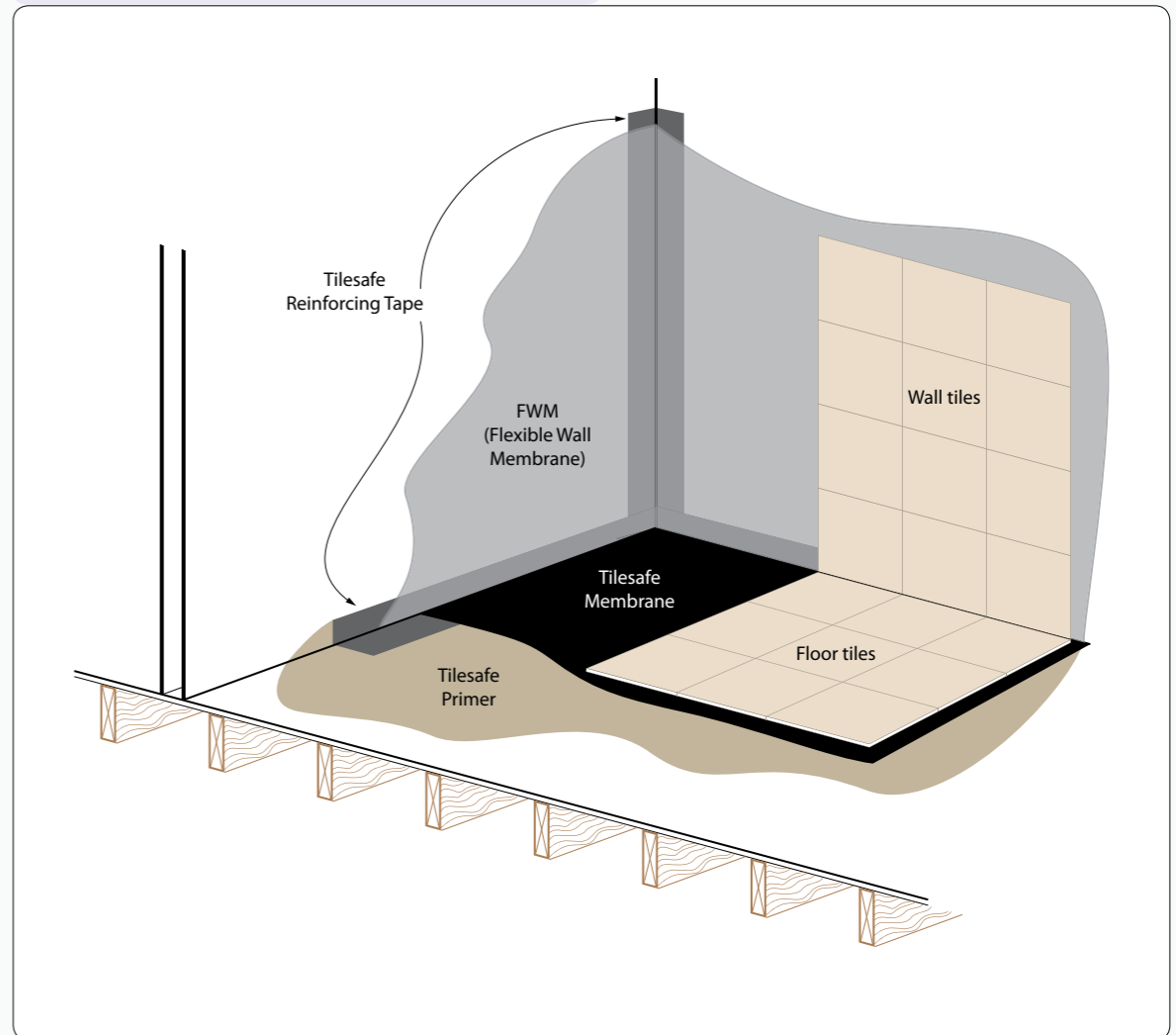

For timber floors we recommend that the Tilesafe membrane is applied to the entire wetroom floor.

For solid floors we recommend that the Tilesafe membrane is applied to the shower area plus an additional one metre in either direction.

FWM should then be applied to the walls of the shower area plus an additional 300mm and overlapped onto the Tilesafe Reinforcing Tape.

5.1 INSTALLATION



ABOUT US



Our extensive experience has shown us that some customers desire the peace of mind of having a complete supply and installation service from the manufacturer, therefore ensuring that responsibility for any subsequent issues lies at one point.

With this in mind we are able to offer a unique supply and fit service through our sister company - Wetrooms UK.

Wetrooms UK Limited is an efficient, professional and experienced company which designs, supplies and installs wetrooms to the highest specification.

The expertise behind the company is based on over 30 years' experience in the waterproofing industry.

We have worked with highly prestigious clients in the hotel, spa and leisure industries as well as many domestic house developers.

This experience enables us to understand your needs to maximise space and create modern, distinctive and beautiful wetrooms, backed up with specialist guarantees and insurances.

KEY FEATURES

- Consultation and design service
- Supply and installation
- Post-application inspection report
- 10 year installation guarantee
- Optional 10 year insured guarantee



5.1 INSTALLATION

BESPOKE DESIGN AND INSTALLATION

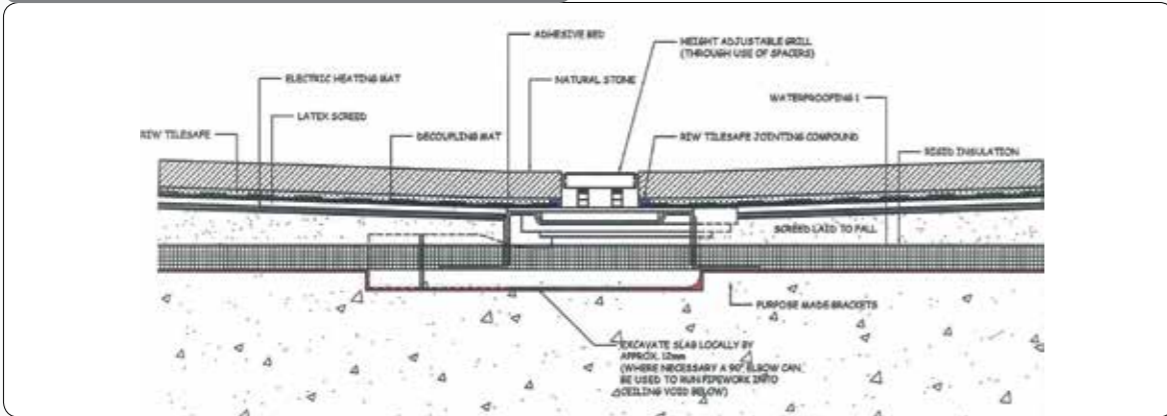

Simplicity and versatility are the key attributes of a fabulous wet room and so too is the bespoke service from Wetrooms UK.

From consultation and design through to supply and installation, we ensure that every detail of your wetroom is absolutely right. Working with architects, design teams and site trades, we create the wetrooms to perfectly fit your requirements.

With our expertise in design and the exclusive use of premium quality products, you can be confident that your wetroom will continue to look and function like new for years to come.

Meeting your expectations to create the ultimate wetroom is our primary focus. This is why our involvement in a project from conception to completion means there is never any compromise on quality.

We simply deliver great design and a beautiful finish.

OUR GUARANTEE

With every installation, Wetrooms UK is able to offer a 10-year company guarantee. In addition we can offer an insured guarantee through Construction Guarantee Services Ltd (CGS), which covers your chosen installation.

Regulated by the Financial Services Authority (FSA), CGS is a completely independent organisation.

- 10 year installation guarantee
- Optional 10 year insured guarantee



Wetrooms UK provide you with peace of mind - guaranteed.

5.1 INSTALLATION

WHAT WE PROVIDE

CONSULTATION AND DESIGN

Our bespoke design service addresses every detail of your wetroom. In addition to creating the right design for each space, we ensure that any potential installation or maintenance issues are eliminated.

TRAINING AND AFTER SALES SERVICE

From classroom and on-site training, to site inspection and testing, we ensure your trades people work to the same high standards to achieve a quality finish.

SUPPLY AND INSTALLATION

With Wetrooms UK you have the peace of mind of our supply and installation service, backed up by our 10 year insured guarantee.

OUR PORTFOLIO

Please see a selection of our clients below.

Hilton

Through our excellent partnership with a leading bespoke glass manufacturer, Wetrooms UK has supplied and installed the wet areas for 75 ensuite bathrooms.



Savoy

For each one of the 110 rooms at this prestigious hotel, Wetroom UK's premium waterproof membrane was the specifier's choice.



Octagon

For every luxurious new home developed by Octagon, our products and services are a required specification.



5.1 INSTALLATION

CASE STUDY 1 - THE HOTEL

REQUIREMENTS & ISSUES

For this prestigious London hotel, the client requested that all 75 wetrooms had level access and were designed to incorporate large format, whole tiles (without any diagonal cuts for fitting).

Each wetroom was also to be fitted with a linear drain with a screed depth of only 60mm from the concrete slab. In addition, the client also required the rooms to be fully waterproofed including full height on the shower walls and one metre on the wall around the bath area.



SOLUTION

Due to the existing screed depth and the requirement to provide level access, we used the CCL Wetrooms Linear Screed Drain, with an adapted height-adjustable fixing bracket.

The top screed was completely removed in the floor area of the shower (1200mm x 900mm). The concrete slab around the trap and waste area was removed locally to install the trap at the required depth.

The screed in the shower area was then re-laid having gained the 12-15mm fall.

RiW Tilesafe membrane was then installed to all corner-to-corner junctions on the wall and across the entire floor, finishing 75mm up the wall/floor junction. FWM was applied to full height on the walls in the shower and bath areas - linking to the Tilesafe membrane.

CROSS SECTION

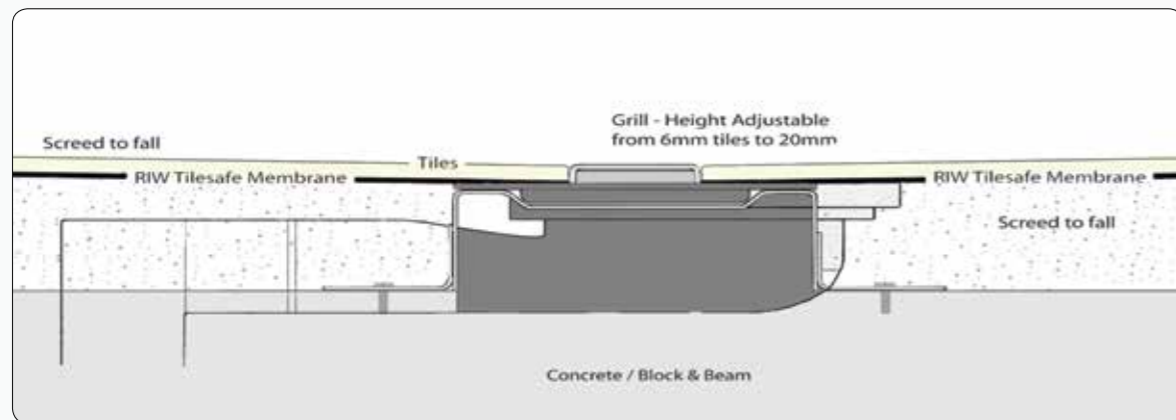

5.1 INSTALLATION

CASE STUDY 2 - STUDENT ACCOMMODATION

REQUIREMENTS & ISSUES

The existing bathroom in this student accommodation in Manchester was in a very poor condition. All 364 pod bathrooms had leaks and the vinyl floor finish was in urgent need of replacing.

In addition, the pod floors were of 18mm plywood, constructed on a steel box section frame, which sat on a concrete slab with all drainage above slab level.

The client now wanted the whole floor area to run to the drain as pooling water had become a serious issue. Easy access to the waste and trap was also required for cleaning purposes.



SOLUTION

The CCL Wetrooms Linear Screed Drain was installed directly into the 18mm ply floor but with a ply-routed plate rather than the standard fixing bracket.

Battens were fixed to the existing timber floor and a rapid-set, flexible levelling compound was poured to lay the whole room to falls. The floor was then fully waterproofed with RiW Tilesafe Membrane.

CROSS SECTION

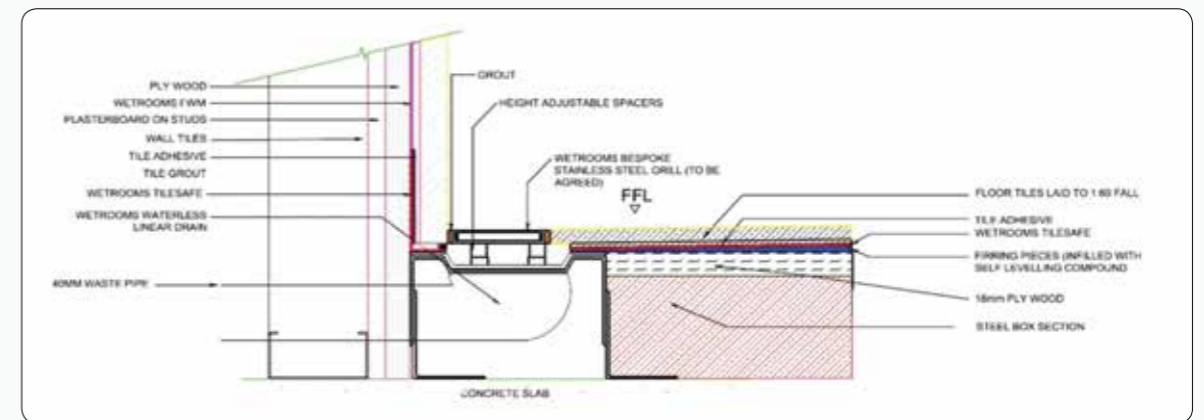

5.1 INSTALLATION

CASE STUDY 3 - LUXURY HOUSING

REQUIREMENTS & ISSUES

This client is a specialist developer of prestigious detached properties in prime town and country locations in the Home Counties.

There are two types of floor construction for these properties: concrete plank or block and beam with insulation and screed, or timber joists and 22mm floorboards.

The required flow rate for the wetrooms must be between 24 litres per minute and 40 litres per minute. All wetrooms are required to have large format tiles or marble slabs.

SOLUTIONS

For concrete plank or block and beam

The CCL Wetrooms Linear Screed Drain was used; however, depending on the flow rate required, the drain was installed with either one or two waste and traps.

To ensure a fully waterproofed wet area, RIW Tilesafe Membrane was installed to the entire floor area, finishing 75mm up the wall/floor junction. FWM was applied to full height on the shower walls linking to the Tilesafe membrane.

For timber joists

The CCL Wetrooms Linear Wet-Dec was used for this type of floor construction.



The Wet-Dec's are available in a range of sizes and are trimmed to fit the required shower area. An 18mm plywood floor was constructed at joist level with waste and traps installed within the joist space.

Up to three of these waste and traps were installed depending on the flow rate required. The Wet-Dec, with its pre-built drainage slopes, then replaced the floorboards in the shower area.

Once the Wet-Dec was installed, the area was fully waterproofed with RIW Tilesafe Membrane and FWM to the full height of the walls.

CROSS SECTIONS

For concrete plank or block and beam

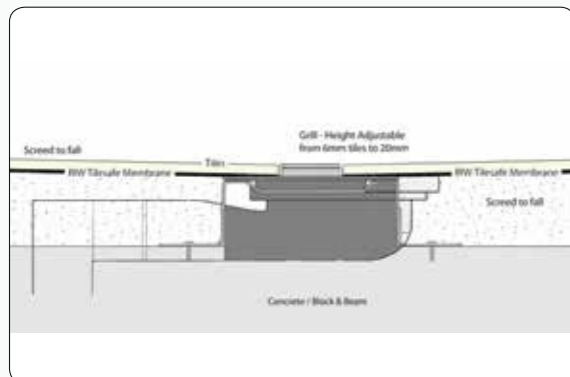

For timber joists

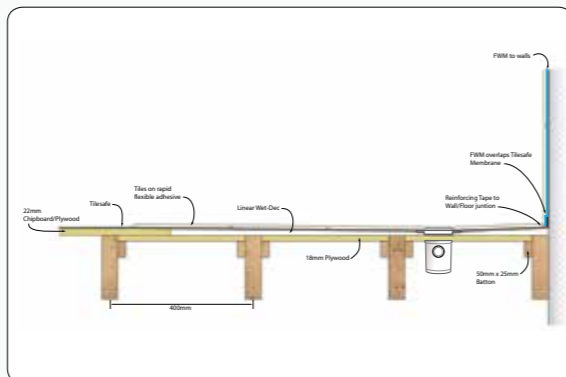

5.1 INSTALLATION

EXPERT INSTALLATION

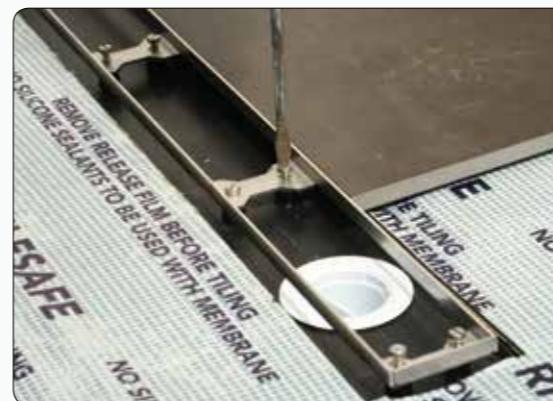

TECHNICAL SUPPORT

For technical assistance please contact our experienced technical department who will be happy to assist in the following:

- Project design
- Product specification
- CAD drawings
- Method statements

TECHNICAL SEMINARS

We are able to provide CPD based seminars designed to provide guidance on key wetroom design considerations such as;

- Design and layout
- Drainage
- Waterproofing
- Flow rates

For further information please contact our technical department.

TECHNICAL ADVICE

Our team of technical advisors are able to visit you to provide a professional advisory service and assist with project design and specification.

We are also able to attend site to provide technical support and assistance.

TECHNICAL ENQUIRIES

TEL: 0844 327 6002

Fax: 01256 765100
technical@ccl-wetrooms.co.uk
www.ccl-wetrooms.co.uk

CCL Specialist Supplies Ltd

Lodge Farm
Hook Road
North Wamborough
Hook
RG29 1HA



INSTALLATION

With over 30 years experience in the waterproofing industry, our involvement in a project from conception to completion ensures that quality is never compromised.

Our services include;

- Design and installation
- 10 Year Insured Installation guarantee
- On-site training

INSTALLATION ENQUIRIES

TEL: 0845 045 6001

Fax: 01256 765100
enquiries@wetroomsuk.co.uk
www.wetroomsuk.co.uk

Wetrooms UK Ltd

Lodge Farm, Hook Road
North Wamborough
Hook
RG29 1HA



part of
the CCL
group



PEACE OF MIND
GUARANTEED