

Linear Screed Line

I.2 b

PRODUCT
SPECIFICATION
GUIDE

CHOOSE LAYOUT

SOLID FLOOR

ONE-WAY FALL

Having a single one-way fall has some significant advantages in both the design and installation of a wetroom shower.

The linear drain is neatly positioned up against the wall, ensuring a sleek, unobtrusive finish, whilst at the same time making it simple to create the gradient using our pre-formed Linear Screed-Dec.

It is also simple to tile, especially when using large format tiles, with no difficult or unsightly cuts required around the drain.

List of products to achieve one-way fall

Drainage - see section 1.2 for full details

- Linear Screed Drain
- Linear Screed Line

Floor build-up - see section 1.3 for full details

- Linear Screed-Dec
- HBL-50 Hi-Build Latex

FAST TRACK bespoke service available - delivered in 3-4 days.

Drain positioned against the long wall.

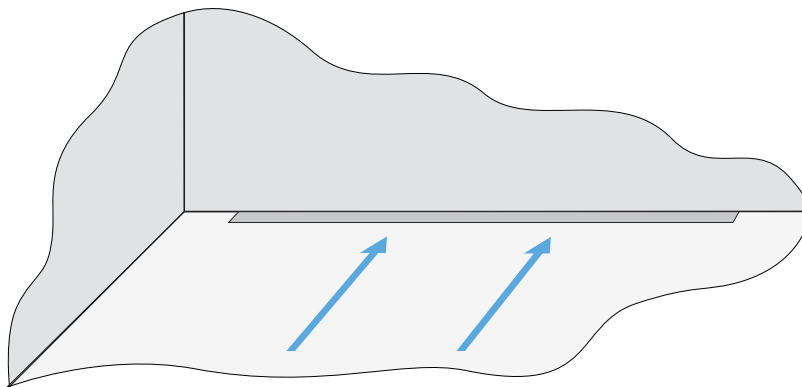

Drain positioned against the short wall.

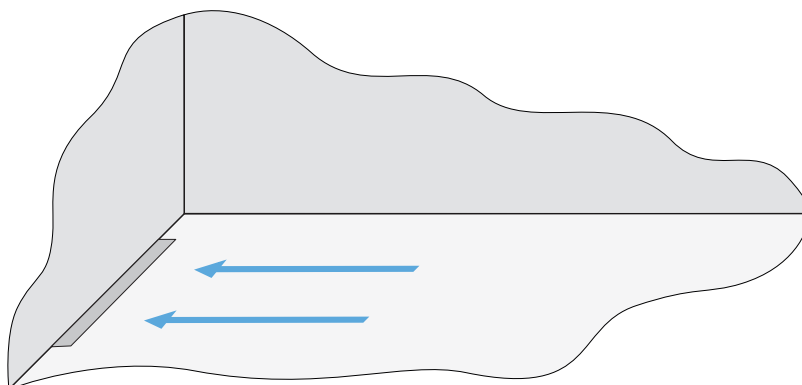

LINEAR SCREED LINE

SOLID
FLOOR



LINEAR SCREED LINE

CHOOSE LAYOUT

SOLID FLOOR

TWO-WAY FALL

With the linear drain positioned off the wall, a two-way fall design maintains a sleek look with the gradient formed in two directions, either side the drain.



THREE-WAY FALL

With the linear drain positioned against the wall, the gradient is formed in three directions towards the drain. Suitable for larger showers exceeding 2000mm and walk-through shower areas.



FOUR-WAY FALL

With the single point drain positioned within the shower area, the gradient is formed in four directions towards the drain. Best suited for mosaic tiles.



LINEAR SCREED LINE

1.1

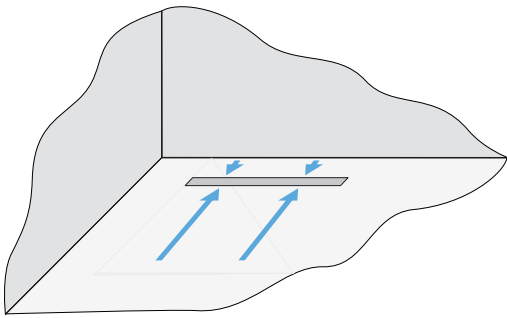

List of products to achieve two-way fall

Drainage - see section 1.2 for full details

- Linear Screed Drain
- Linear Screed Line

Floor build-up - see section 1.3 for full details

- Linear Screed-Dec
- HBL-50 Hi-Build Latex

FAST TRACK bespoke service available - delivered in 3-4 days.

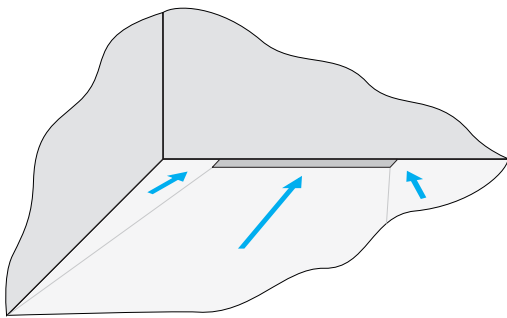

List of products to achieve three-way fall

Drainage - see section 1.2 for full details

- Linear Screed Drain
- Linear Screed Line

FAST TRACK bespoke service available - delivered in 3-4 days.

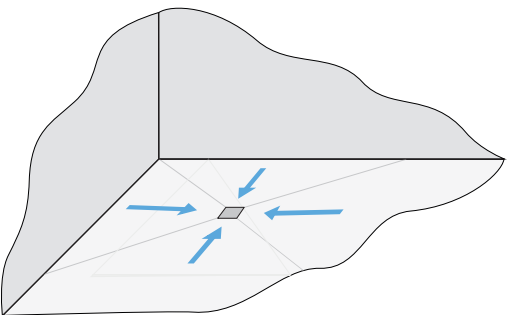

List of products to achieve four-way fall

Drainage - see section 1.4 for full details

- Solo4

SECTION I - SOLID FLOOR DRAINS

I.1 PRODUCT INFORMATION

I.1

I.2 LINEAR DRAINS

I.2 a

A) LINEAR SCREED DRAIN

B) LINEAR SCREED LINE

I.2 b

I.3 FLOOR BUILD UP

I.3 a

A) HI-BUILD LATEX

B) LINEAR SCREED-DEC

I.3 b

I.4 SOLO 4

I.4

SOLID
FLOOR

1.2 b

LINEAR SCREED LINE



Linear Screed Line

Linear Screed Line is a versatile linear drain available in a choice of grill finishes, utilising up to three of our TR-50, 50mm waterseal traps for a maximum flow rate of 68 litres per minute.

With the option of horizontal or vertical outlets, the drain is easily configured to suit almost any solid floor construction, with grill lengths available up to 2000mm.

In addition we also offer a simple floor build-up option, along with a range of waterproofing products to provide a complete wetroom solution, all backed up by our [Lifetime Guarantee](#).

I.2 b



SOLID
FLOOR

1.2 b

LINEAR SCREED LINE

INTRODUCTION

MINIMUM HEIGHT:
STANDARD BRACKETS: 138mm
EXTRA SHALLOW BRACKETS: 38mm



KEY FEATURES

The Linear Screed Line has been designed for concrete or screeded floors for use on concrete slabs, planks and block and beam floors.

The drain incorporates our TR-50 trap which has a 50mm waterseal and is supported by a lifetime guarantee.

Versatility is its key feature, being available with one, two or three traps and a choice of horizontal and vertical outlets.

Available with a choice of stylish grill finishes, the Linear Screed Line will suit almost any application.

1.2 b

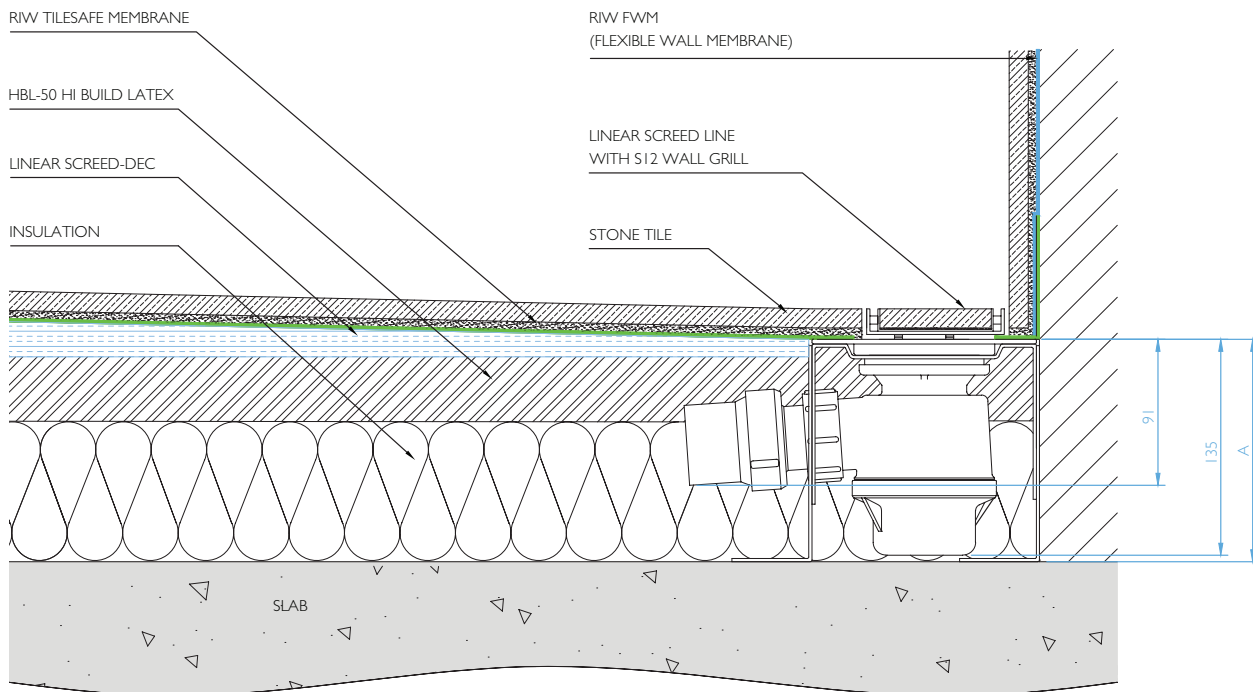

DIMENSION A : MIN. 138mm MAX. 218mm (Extension brackets available) drawn as 139mm.

KEY FEATURES

- Horizontal or Vertical Outlet
- 50mm Waterseal trap EN274-1:2002.
- Flow rate up to 68 L/min ‡¹
- Lifetime Guarantee
- 360° Rotatable outlet
- Centre, left and right handed trap position
- Height adjustable brackets & grill
- Grill lengths up to 2000mm
- **FAST TRACK** Bespoke service:
Delivered in 3-4 days

‡¹ See page 8 for full details.

HOW TO BUILD YOUR DRAIN

There are two components required to specify a Linear Screed Line - the drain body and the grill. To specify the drain body, select the required number of traps along with the bracket type. Then simply choose the grill, selecting the desired type, length and finish.

DRAIN BODY



Number of traps

- Single Trap - flow rate up to 24 L/min
- Double Trap - flow rate up to 41 L/min
- Triple Trap - flow rate up to 68 L/min

See page 8 for full details

Type of trap

- Horizontal Outlet
- Vertical Outlet

See page 9 for full details

Bracket type

- Standard Height - adjustment 138mm-218mm
- Extra Shallow Height - adjustment 38mm-57mm

See page 9 for full details

GRILL



Grill type - Wall or Floor

- Floor Grill - for installation off the wall
- Wall Grill - positioned neatly up against the wall

See page 10 for full details

Grill length

- 15 Standard lengths
- Bespoke lengths from 600mm - 2000mm
- **FAST TRACK** Bespoke service - delivered in 3-4 days

See page 11 for full details

Grill finish

- 5 Stylish grill finishes

See page 13 for full details

NUMBER OF TRAPS

The Linear Screed Line has a 50mm waterseal top access trap designed specifically for wetroom installations, manufactured to EN274-1:2002.

The smart design of the linear trough allows the trap position to be positioned on-site, in a central, left or right hand position and can be rotated through 360° enabling installation in most scenarios with ease.

- 50mm Waterseal
- 360° Rotatable outlet
- Centre, left and right handed trap position
- Top access for easy maintenance
- Lifetime Guarantee



24 L / min

Single Trap

- Flow rate up to 24 L/min[‡]
- Variable trap position (centre shown)
- Left and right handed option also available
- Outlet position rotates through 360°



41 L / min

Double Trap

- Flow rate up to 41 L/min[‡]
- For medium-high performance showers
- Variable trap position (centre, left or right)
- Outlet position rotates through 360°



68 L / min

Triple Trap

- Flow rate up to 68 L/min[‡]
- For high performance showers
- Outlet position rotates through 360°

[‡] Flow rates indicated are a guide only, based upon 42mm waste pipe and swept bends. See pages 16 & 17 for product codes.

TRAP OUTLETS

HORIZONTAL TRAP

The horizontal trap incorporates an adjustable ball joint, allowing for ease of installation and can be positioned centre, left or right handed and is accessible from the top for cleaning and maintenance.

- 50mm Waterseal
- 40mm ABS pipe connection

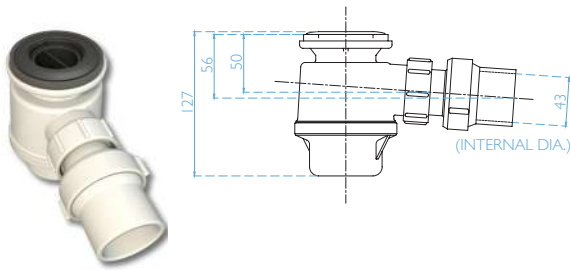

VERTICAL TRAP

The vertical trap allows the outlet to be positioned through the slab and connected to a waste pipe below and can be positioned centre, left or right handed and is accessible from the top for cleaning and maintenance.

- 50mm Waterseal
- 50mm ABS pipe connection

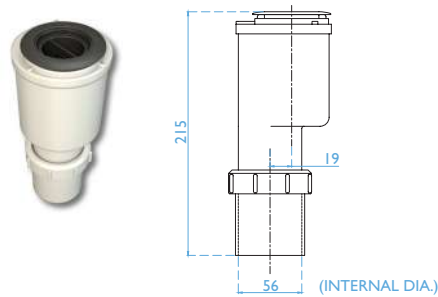

I.2 b

BRACKET TYPE

HORIZONTAL TRAP

Standard Bracket

Adjustable between 138mm - 218mm.

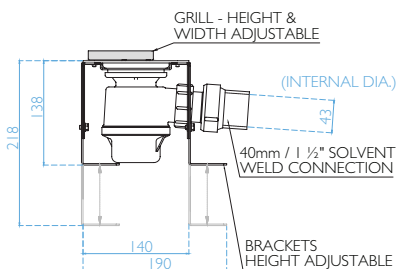

VERTICAL TRAP

(available in two options)

Standard Bracket

Adjustable between 55mm - 88mm.

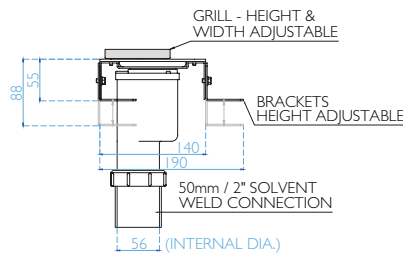
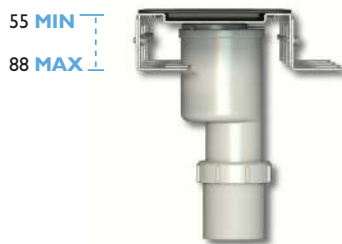

Extra Shallow Bracket

Adjustable between 38mm - 57mm.

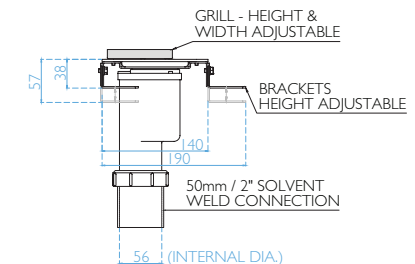
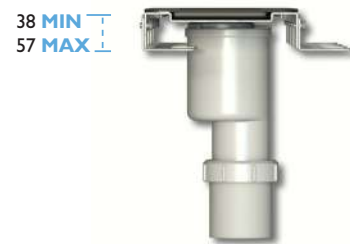

GRILL TYPE - WALL OR FLOOR

There are two types of grill available with the Linear Screed Drain, both fit onto the drain body using 8 pre-set fixing points.

Both the Floor Grill and Wall Grill are independently height adjustable, enabling the grill to be positioned precisely to suit the tile thickness being used.

The final position of the Wall Grill is also independently width adjustable by up to 38mm, allowing the grill to be neatly positioned up against the wall tile, after the drain body has been installed, for a perfect finish every time.

All grills are manufactured in 316 grade stainless steel ensuring a stunning high quality durable finish.

FLOOR GRILL

The centre point of the Floor Grill is typically positioned 150mm from the wall, to create a two-way fall within the shower: **Grill width 58mm.**

WALL GRILL

The Wall Grill is positioned neatly up against the wall, to create a one-way fall within the shower: **Grill width 86mm.**

1.2 b

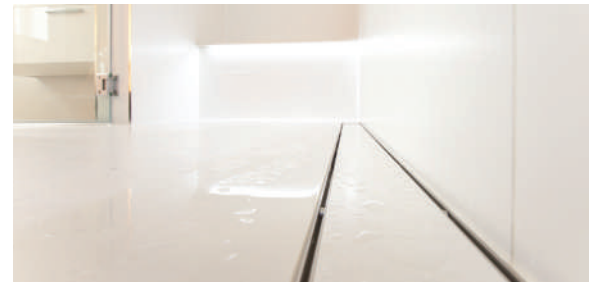
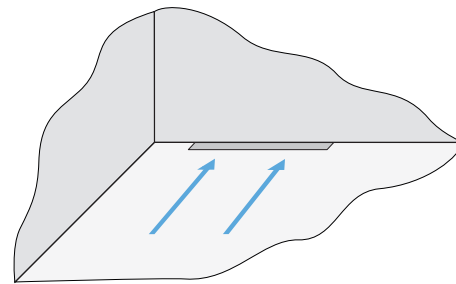
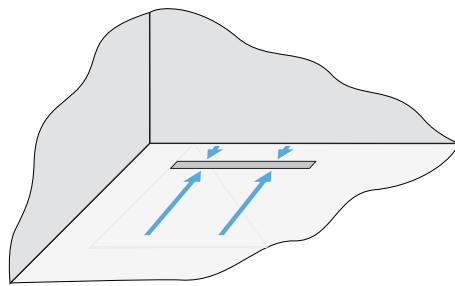
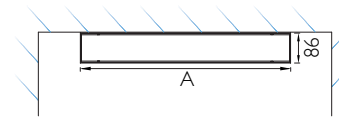
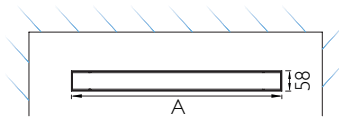

HEIGHT ADJUSTMENT

The Floor Grill is independently height adjustable in 1mm increments to suit different tile thicknesses.

The Wall Grill is independently height adjustable in 1mm increments to suit different tile thicknesses. The final position of the Wall Grill is also independently width adjustable by up to 38mm.

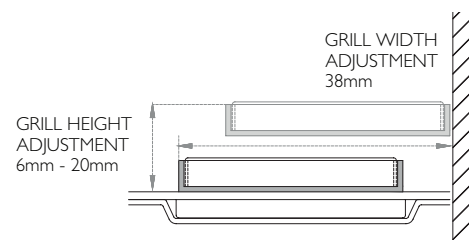
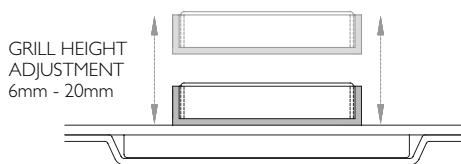

See pages 16 & 17 for product codes.

GRILL LENGTH

All grill types are offered in 15 standard lengths ranging from 600mm to 2000mm, with the majority available from stock on a next day delivery service.^{‡1}

Where a standard grill length is not suitable we offer a **FAST TRACK** bespoke design service, manufactured and delivered in as little as 3-4 days. See below for further details.

The drain body is always installed first, prior to the application of the waterproofing membrane, with the grill installed at the point of tiling.

Regardless of the length of grill, the drain body always remains the same at 660mm. Where the grill length exceeds 660mm the ends of the grill overhang the drain body and are supported with tile adhesive - see image below.

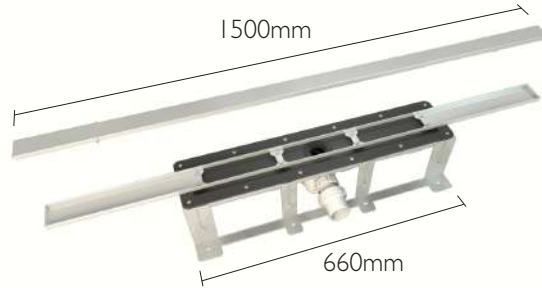
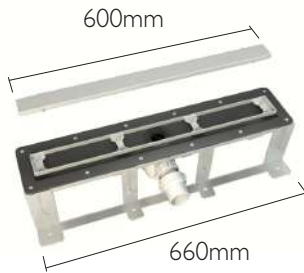

The following standard grill lengths are available:

- 600mm
- 700mm
- 800mm
- 900mm
- 1000mm
- 1100mm
- 1200mm
- 1300mm
- 1400mm
- 1500mm
- 1600mm
- 1700mm
- 1800mm
- 1900mm
- 2000mm

^{‡1} Excludes grill types B & C greater than 1500mm.

For grill types S & F greater than 1500mm; the Insert is supplied in two equal sections.

Offset grill position available as a bespoke - see below for details.

FAST TRACK BESPOKE

Where a standard grill length is not sufficient to meet the requirements of a project, such as when designing the drain to fit exactly between two walls, a bespoke length may be required.

We understand the exact grill length required may not be known until the shower has been tiled, therefore to meet such requirements we offer a unique **FAST TRACK** production service, where we can manufacture and deliver a bespoke length grill in 3-4 days.

We can achieve this due to the unique design of our drain, with the drain body supplied separately, and the grill to follow.

- Any length grill between 600mm-2000mm
- Manufactured in 2-3 days and delivered in 3-4 days.
- Grill types A, S8, S12, S20 & F
- No drawing required ^{‡2}

^{‡2} Subject to drain body being installed centrally within the shower area.

BESPOKE GRILL DESIGN

We also offer a bespoke design service where we can manufacture a grill to a specific width or height, or to a completely unique design, usually within 2-3 weeks. Please contact our technical team for further information.

Wall to wall grill

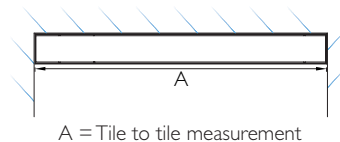

Where a wall to wall grill finish is required it is recommended to take a measurement on-site from the face of the wall tiles, therefore ensuring there are no gaps either side of the grill. The grill is manufactured in 2-3 days and delivered in 3-4 days using our **FAST TRACK** bespoke grill service.

See pages 16 & 17 for product codes.

SOLID
FLOOR

1.2 b

LINEAR SCREED LINE

FRAMELESS GRILL

With only a shadow gap visible around the perimeter of the drain, the stunning Frameless Grill ensures water drains effortlessly away, providing a sleek, contemporary finish to any room.

Frameless design complements all brassware finishes.

GRILL FINISH

Ultimately the grill finish is the only visible element of our wetroom system and as such, is often the defining factor of the overall design.

From the contemporary Stone-Infill or ultra-stylish Frameless, to the simplicity of the Brushed stainless steel, we have a grill finish to complement any design style.

We manufacture all of our grills using only 316 marine grade stainless steel, ensuring a stunning high quality durable finish, complete with our Lifetime Guarantee.

The grill insert is easily removed for cleaning and maintenance, using the key provided with the grill.



BRUSHED STAINLESS STEEL

- Choice of designs in a metallic finish.

Type A - Solid

With a 5mm gap around the grill for a sleek stylish finish.

Type A



Type B - Slotted

Holes with a brushed stainless steel finish.

Type B



Type C - Square

Designed with a brushed stainless steel finish.

Type C



STONE-INFILL

- Allows a section of matching stone or tile to be inserted.

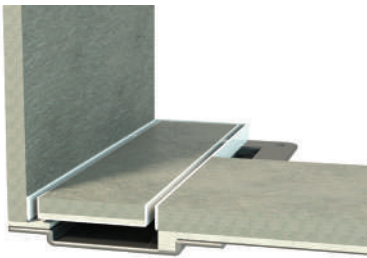

Type S8 - Stone-Infill †¹

Suits 6-8mm stone thickness.

Type S8



Type S12 - Stone-Infill †¹

Suits 10-12mm stone thickness.

Type S12



Type S20 - Stone-Infill †¹

Suits 18-20mm stone thickness.

Type S20



FRAMELESS

- Ensures a stunning almost invisible finish, using a section of matching stone or tile. Frameless design complements all brassware finishes.

Type F - Frameless Grill †¹

Suits any stone thickness.

Type F



Stock lengths 600mm - 2000mm. Bespoke lengths manufactured and delivered in as little as 3-4 days.

All grill finishes are kept in stock, see page 11-12 for available lengths and details of our bespoke manufacturing service.

See pages 16 & 17 for product codes.

†¹ For grill types S & F greater than 1500mm, the insert is supplied in two equal sections. Suitable for stone and porcelain tiles only.

WETROOM COMPONENTS

1.2 b

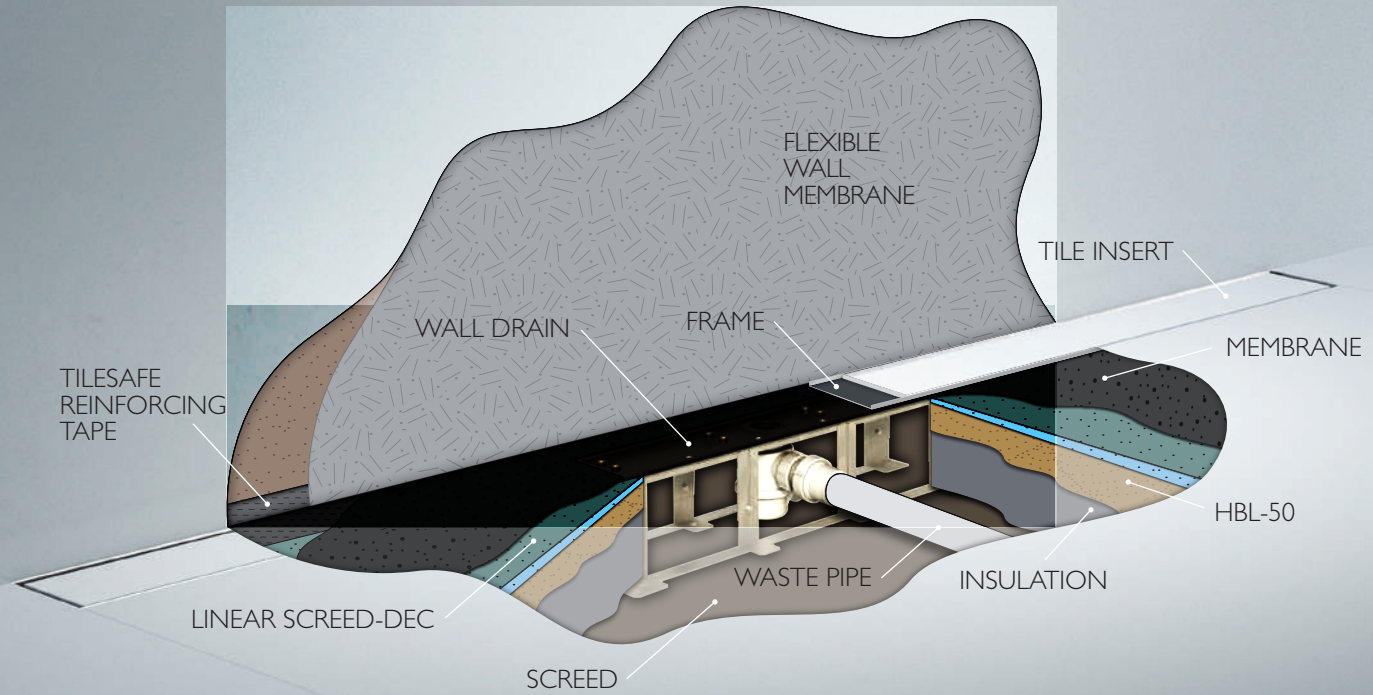

FLOOR BUILD-UP & WATERPROOFING

LINEAR SCREED-DEC

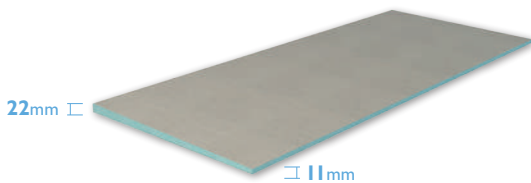

The Linear Screed-Dec is a pre-formed tapered board which removes the uncertainty of forming a fall within the screed in the shower area by hand.

Each board has a pre-engineered one-way fall, providing a guaranteed consistent gradient every time - see section 1.3 for full details.

HBL-50



HBL-50 is a hi-build wetrooms levelling compound specifically designed to provide a sound and stable base for the Linear Screed-Dec, while at the same time allowing for any on-site tolerances - see section 1.3 for full details.

1.2 b

WATERPROOFING

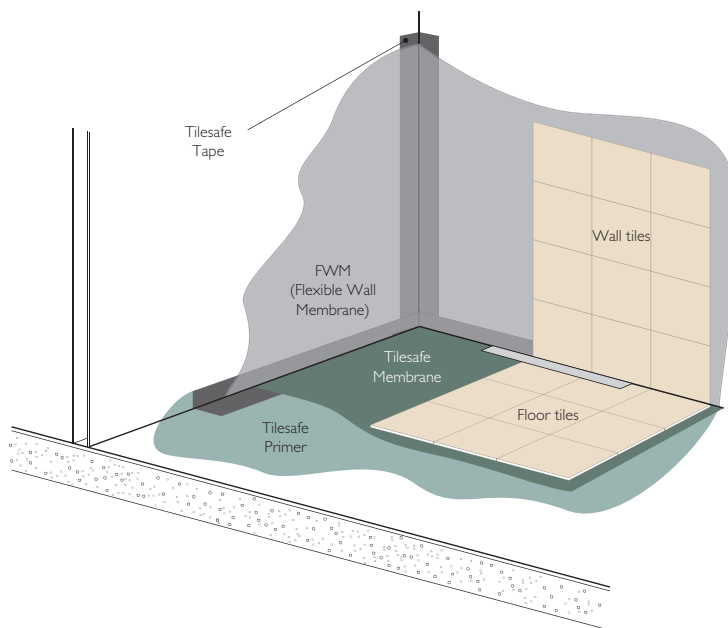

Waterproofing is one of the key elements of any wetroom, ensuring the room remains watertight at all times.

To ensure your entire project is fully covered by our Lifetime Guarantee we have developed a range of unique waterproofing solutions. These are specifically designed and guaranteed to work with our Linear Screed Drain, to provide a complete solution and total peace of mind.





- Floor and wall membrane
- De-coupling properties
- Acoustic properties
- Quick and easy to apply
- Lifetime Guarantee

See Section 3 for full details.





PRODUCT CODES - DRAIN BODY



HORIZONTAL TRAP - STANDARD BRACKETS





TYPE	DRAIN & FLOW RATE	TRAPS	CODE
 138 MIN 218 MAX	 24 L / min	1	LSL-1H/ST
	 41 L / min	2	LSL-2H/ST
	 68 L / min	3	LSL-3H/ST

VERTICAL TRAP - STANDARD BRACKETS

TYPE	DRAIN & FLOW RATE	TRAPS	CODE
 55 MIN 88 MAX	 24 L / min	1	LSL-1V/ST
	 41 L / min	2	LSL-2V/ST
	 68 L / min	3	LSL-3V/ST

Extension brackets available to increase maximum height. Please see below.

VERTICAL TRAP - EXTRA SHALLOW BRACKETS

TYPE	DRAIN & FLOW RATE	TRAPS	CODE
 38 MIN 57 MAX	 24 L / min	1	LSL-1V/ES
	 41 L / min	2	LSL-2V/ES
	 68 L / min	3	LSL-3V/ES

Extension brackets available to increase maximum height. Please see below.

Use extension brackets to increase the height of the standard drain above 88mm. Each bracket will increase the height by 30mm, multiple brackets can be used if necessary.

PRODUCT CODES - GRILL



SOLID FLOOR

WALL GRILL

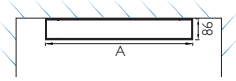

LENGTH	CODE	GRILL FINISH
600mm	SWG-600/-	Add code for Grill Finish:
700mm	SWG-700/-	
800mm	SWG-800/-	
900mm	SWG-900/-	
1000mm	SWG-1000/-	
1100mm	SWG-1100/-	
1200mm	SWG-1200/-	
1300mm	SWG-1300/-	
1400mm	SWG-1400/-	
1500mm	SWG-1500/-	
1600mm † ^{1,2}	SWG-1600/-	
1700mm † ^{1,2}	SWG-1700/-	
1800mm † ^{1,2}	SWG-1800/-	
1900mm † ^{1,2}	SWG-1900/-	
2000mm † ^{1,2}	SWG-2000/-	
FAST TRACK Bespoke † ³	SWG-FT/-	
Bespoke † ^{1,2}	SWG-BES/-	

Stone-Infill options:

- S8** = Suits 6-8mm tile thickness
- S12** = Suits 10-12mm tile thickness
- S20** = Suits 18-20mm tile thickness
- F** = Suits any tile thickness

Brushed stainless steel options:

- A** = Solid
- B** = Slotted
- C** = Square

See p13 for full details.

Example:

Grill Type - Grill Length / Grill Finish
SWG - 1100 / S20

1.2 b

FLOOR GRILL

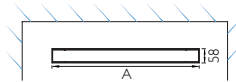

LENGTH	CODE	GRILL FINISH
600mm	SFG-600/-	Add code for Grill Finish:
700mm	SFG-700/-	
800mm	SFG-800/-	
900mm	SFG-900/-	
1000mm	SFG-1000/-	
1100mm	SFG-1100/-	
1200mm	SFG-1200/-	
1300mm	SFG-1300/-	
1400mm	SFG-1400/-	
1500mm	SFG-1500/-	
1600mm † ^{1,2}	SFG-1600/-	
1700mm † ^{1,2}	SFG-1700/-	
1800mm † ^{1,2}	SFG-1800/-	
1900mm † ^{1,2}	SFG-1900/-	
2000mm † ^{1,2}	SFG-2000/-	
FAST TRACK Bespoke † ³	SFG-FT/-	
Bespoke † ^{1,2}	SFG-BES/-	

Stone-Infill options:

- S8** = Suits 6-8mm tile thickness
- S12** = Suits 10-12mm tile thickness
- S20** = Suits 18-20mm tile thickness
- F** = Suits any tile thickness

Brushed stainless steel options:

- A** = Solid
- B** = Slotted
- C** = Square

See p13 for full details.

Example:

Grill Type - Grill Length / Grill Finish
SFG - 1100 / S20

†¹ For grill types B & C: 2-3 week lead-time.

†² For grill types S & F greater than 1500mm, the insert is supplied in two equal sections.

†³ Fast track service: Manufactured and delivered in 3-4 days, maximum length 2000mm.

DETAIL: HORIZONTAL TRAP - WALL GRILL

WALL GRILL WITH STANDARD BRACKETS

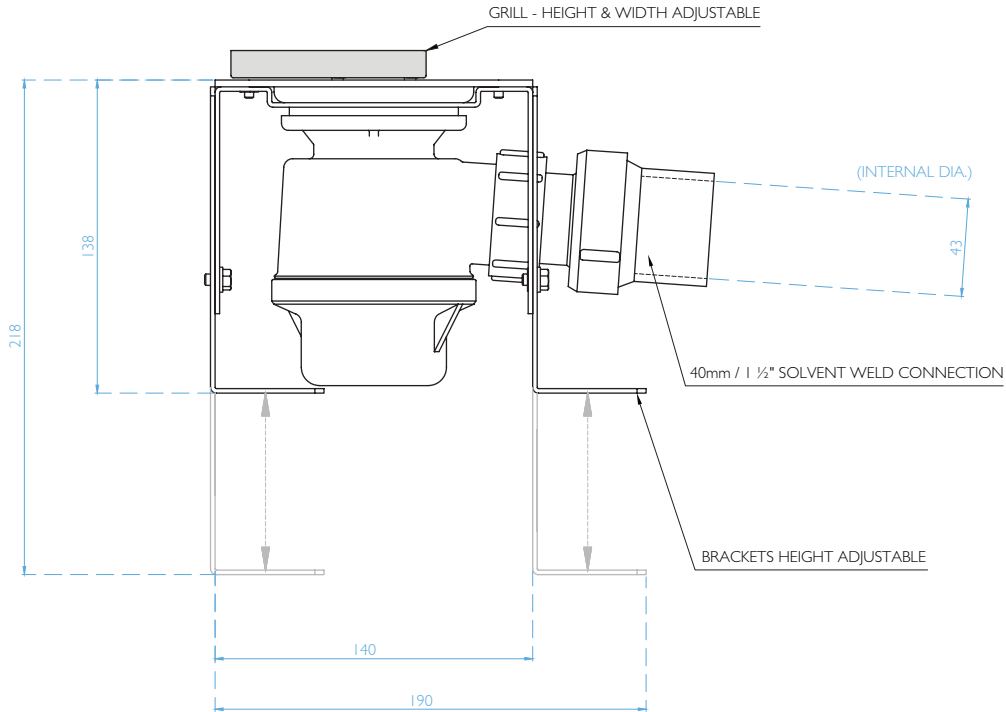

WALL GRILL WITH STANDARD BRACKETS

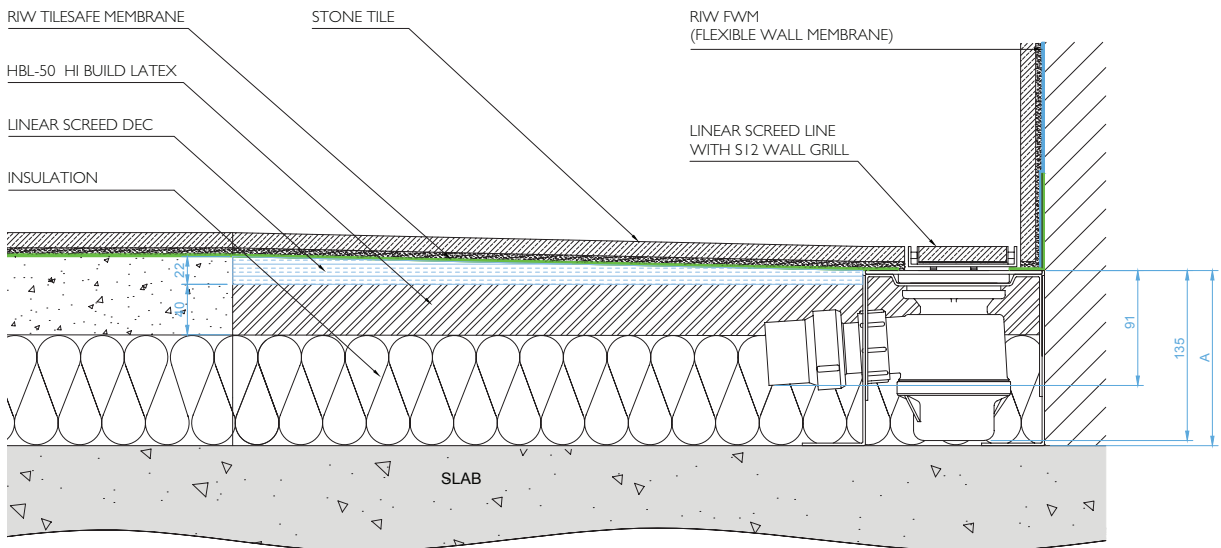

DIMENSION A : MIN. 138mm MAX. 218mm (Extension brackets available) drawn as 139mm.

DETAIL: HORIZONTAL TRAP - FLOOR GRILL

FLOOR GRILL WITH STANDARD BRACKETS

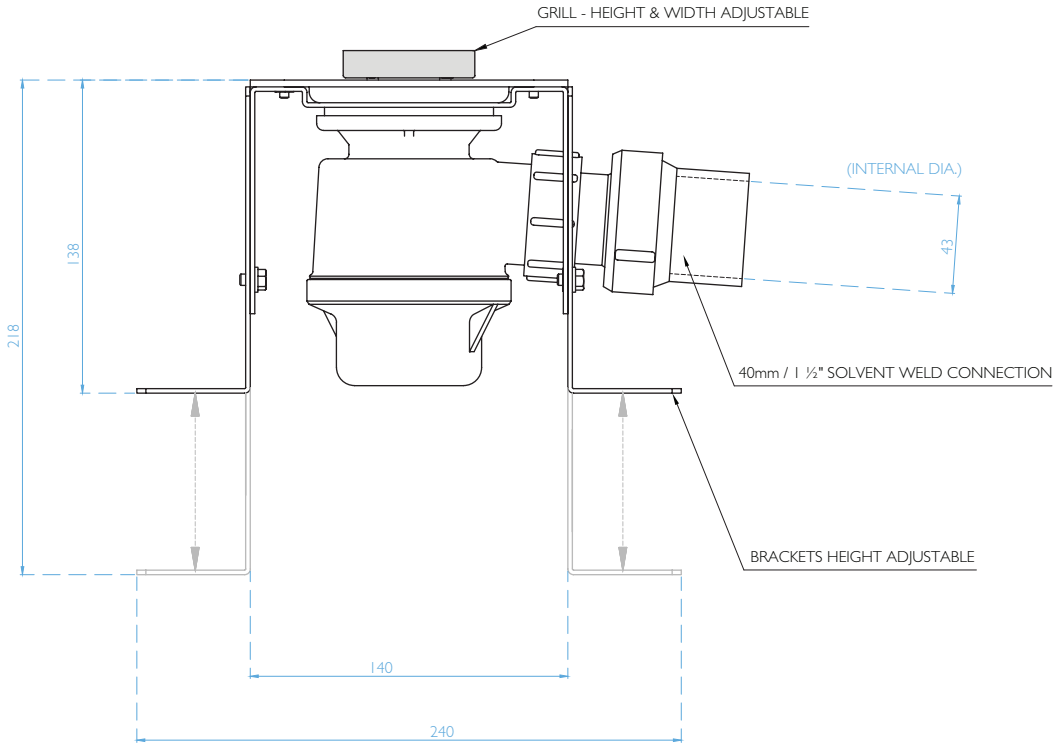

FLOOR GRILL WITH STANDARD BRACKETS

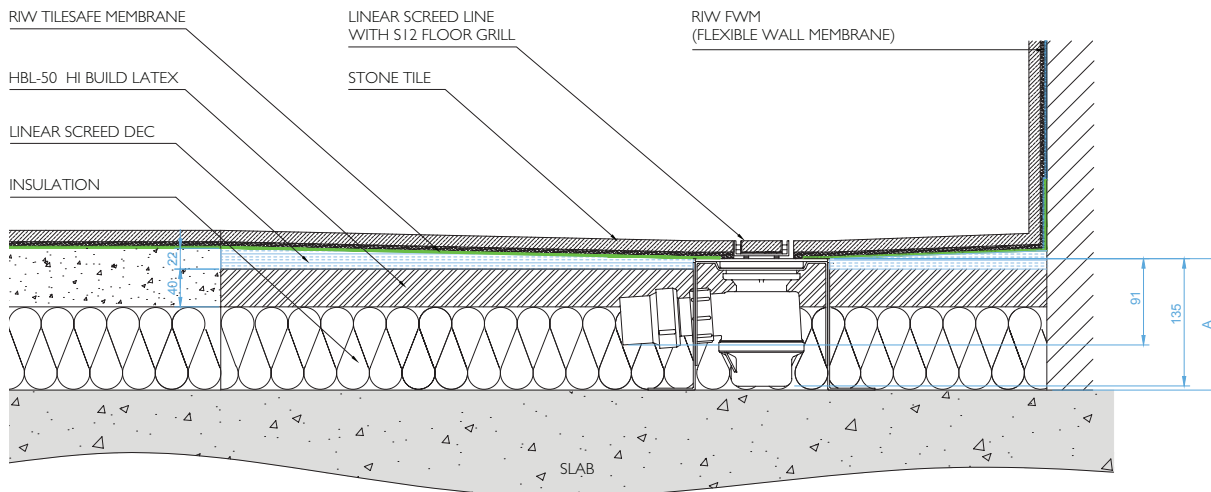

DIMENSION A : MIN. 138mm MAX. 218mm (Extension brackets available) drawn as 139mm.

DETAIL: VERTICAL TRAP - WALL GRILL

STANDARD BRACKETS

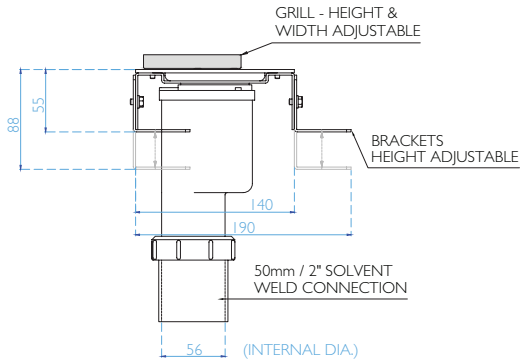

EXTRA SHALLOW BRACKETS

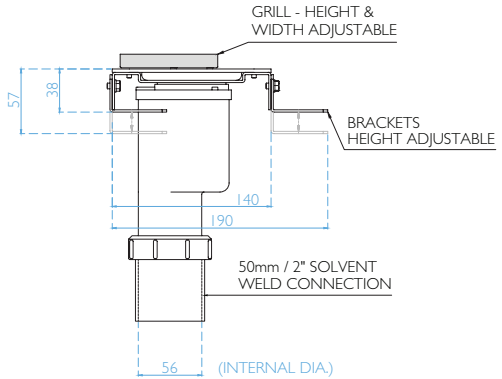

WALL GRILL WITH STANDARD BRACKETS

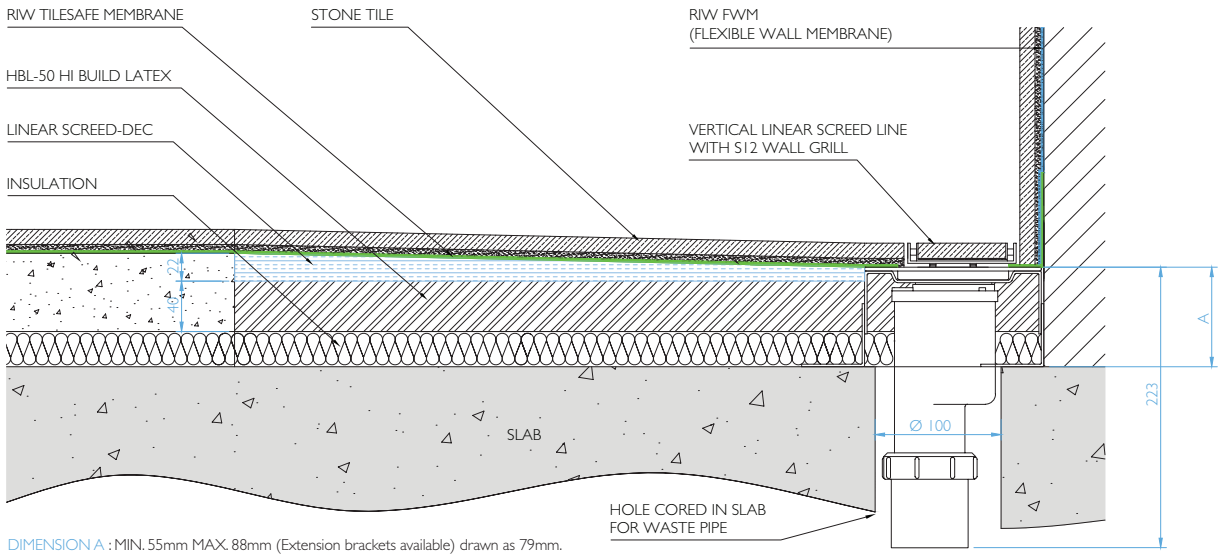

WALL GRILL WITH EXTRA SHALLOW BRACKETS

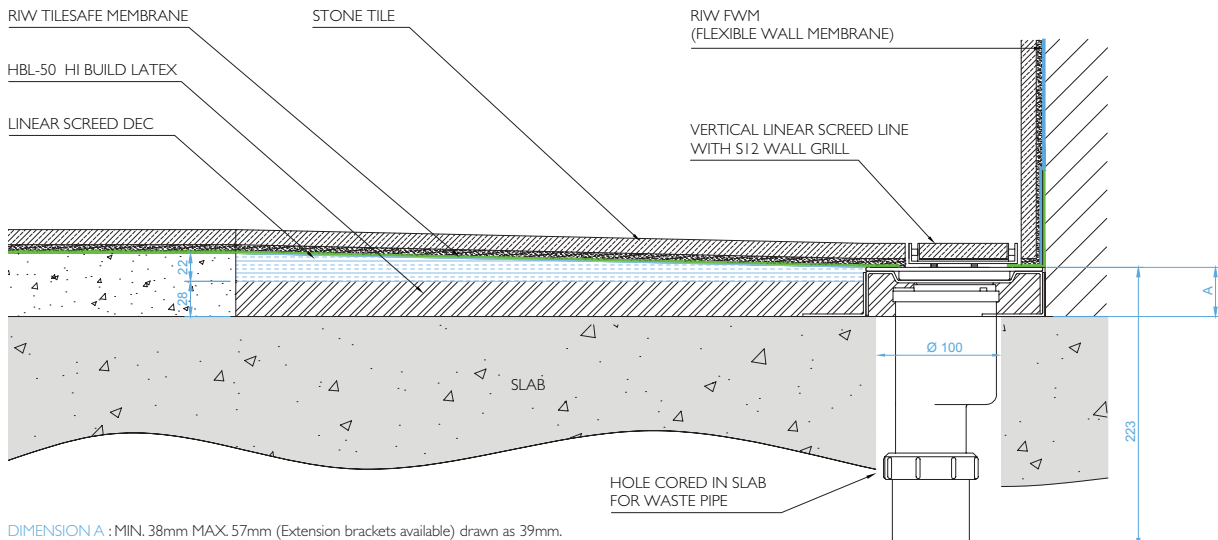

1.2 b

LINEAR SCREED LINE

DETAIL: VERTICAL TRAP - FLOOR GRILL

STANDARD BRACKETS

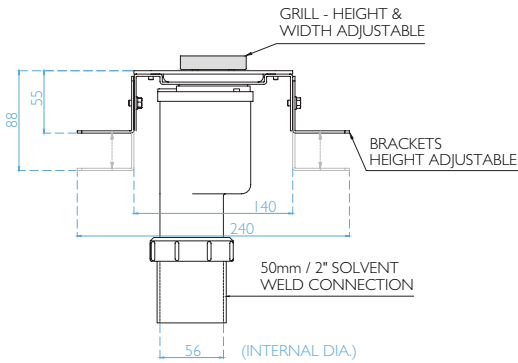

EXTRA SHALLOW BRACKETS

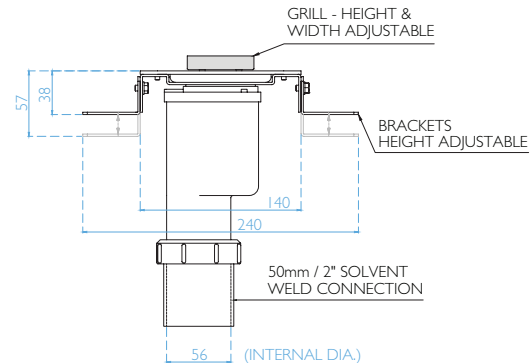

FLOOR GRILL WITH STANDARD BRACKETS

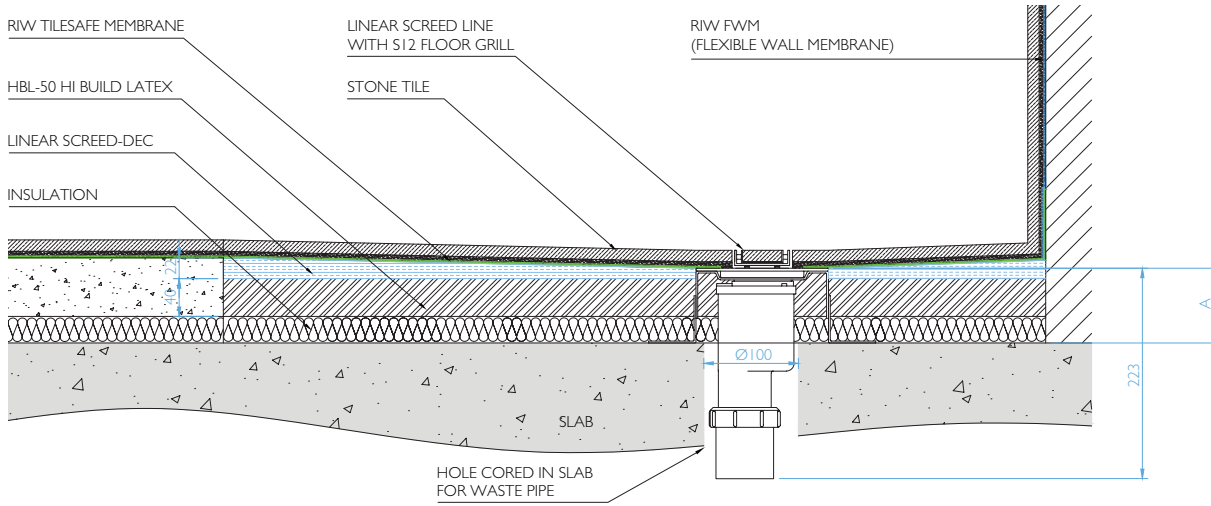

DIMENSION A : MIN. 55mm MAX. 88mm (Extension brackets available) drawn as 79mm.

FLOOR GRILL WITH EXTRA SHALLOW BRACKETS

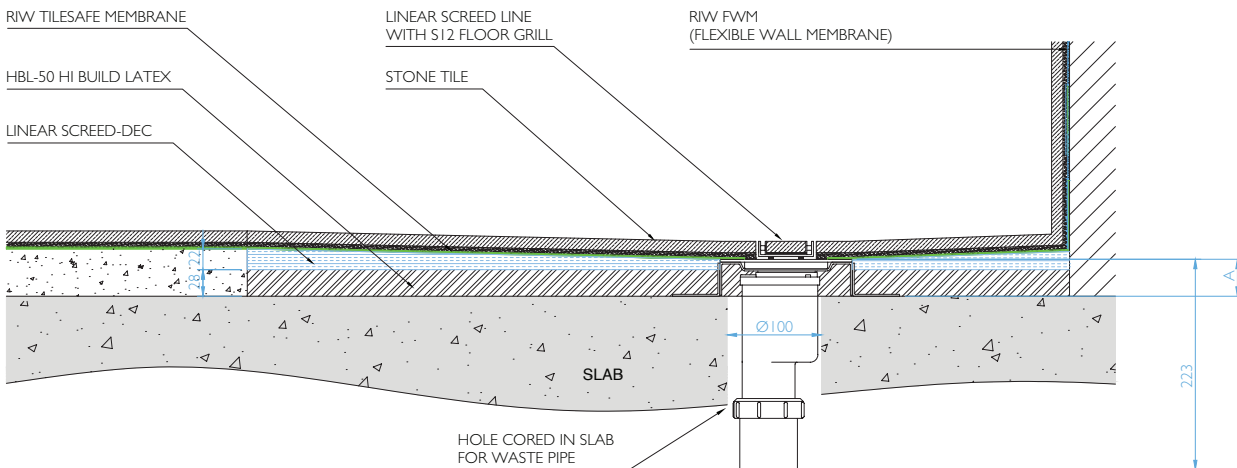

DIMENSION A : MIN. 38mm MAX. 57mm (Extension brackets available) drawn as 39mm.

TYPICAL DETAIL WITH WALL GRILL

SOLID FLOOR

- Use to create a **one-way fall**
- Minimum height 55mm with Standard Brackets
- Minimum height 38mm with Extra Shallow Brackets^{‡1}
- **IO-SEAL** waterless trap
- 360° Rotatable waste outlet
- Centre, left and right handed waste position
- Flow rate up to 68 L/min^{‡2}
- Height adjustable brackets
- Grill lengths up to 2000mm

^{‡1} Requires drain outlet to be recessed into the slab, refer to drawing on pages 18 & 19.

^{‡2} See page 8 for full details.

CENTRAL TRAP

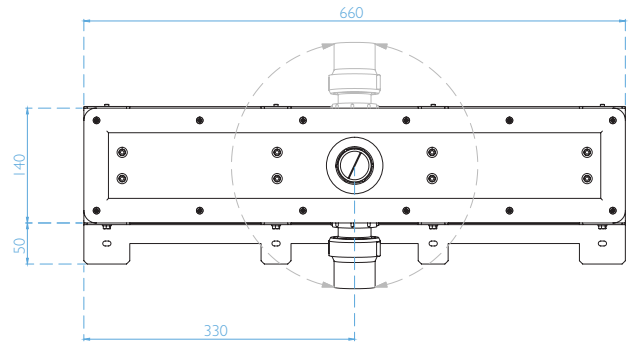

LEFT HAND TRAP

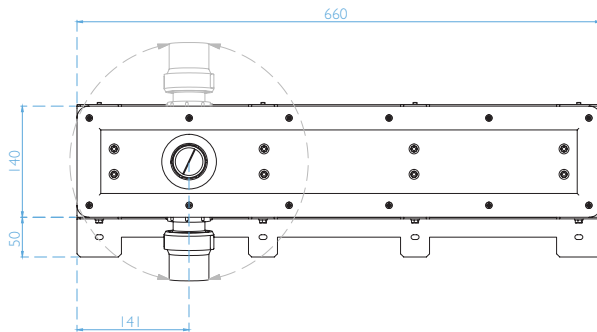

RIGHT HAND TRAP

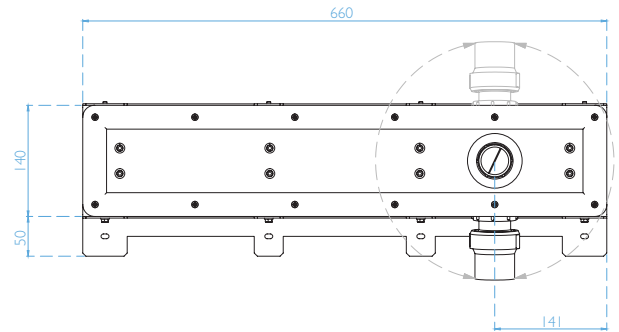

DOUBLE TRAP

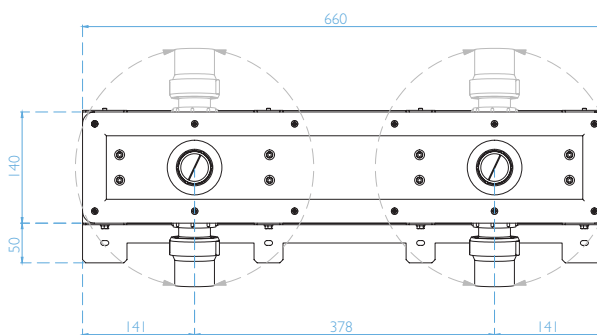

TRIPLE TRAP

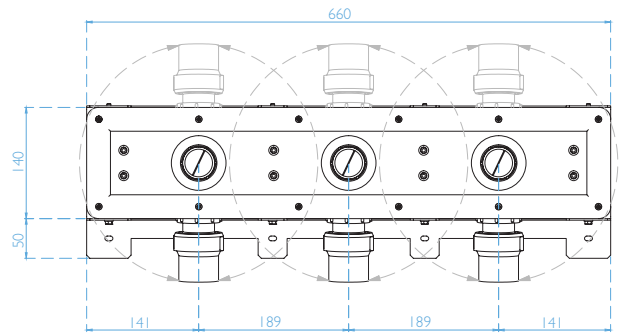

TYPICAL DETAIL WITH FLOOR GRILL

- Use to create a **two-way fall**
- Minimum height 55mm with Standard Brackets
- Minimum height 38mm with Extra Shallow Brackets ^{‡1}
- **Q-SEAL** waterless trap
- 360° Rotatable waste outlet
- Centre, left and right handed waste position
- Flow rate up to 68 L/min ^{‡2}
- Height adjustable brackets
- Grill lengths up to 2000mm

^{‡1} Requires drain outlet to be recessed into the slab, refer to drawing on pages 18 & 19.

^{‡2} See page 8 for full details.

CENTRAL TRAP

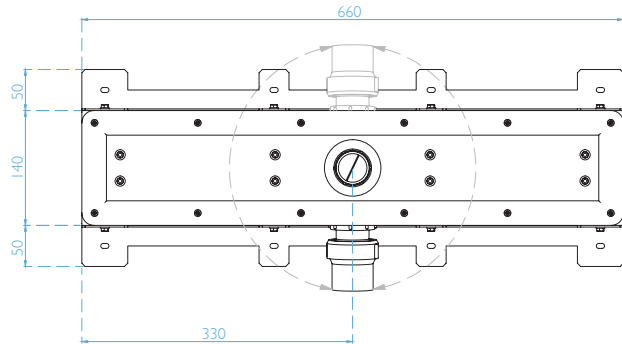

LEFT HAND TRAP

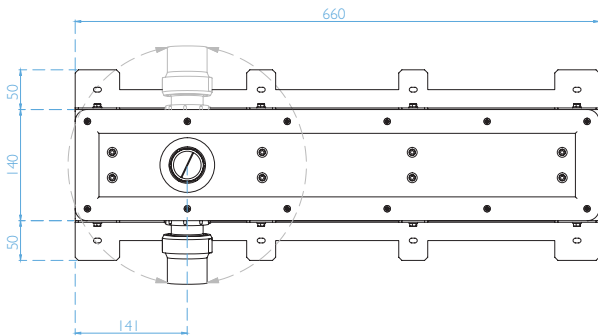

RIGHT HAND TRAP

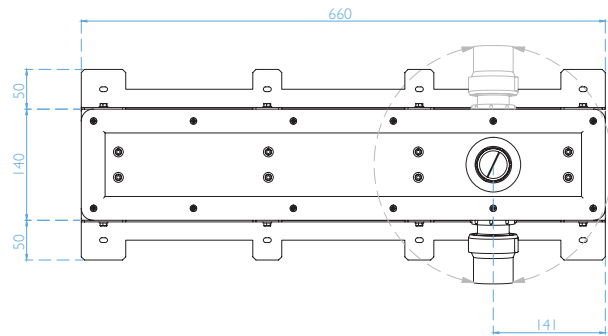

DOUBLE TRAP

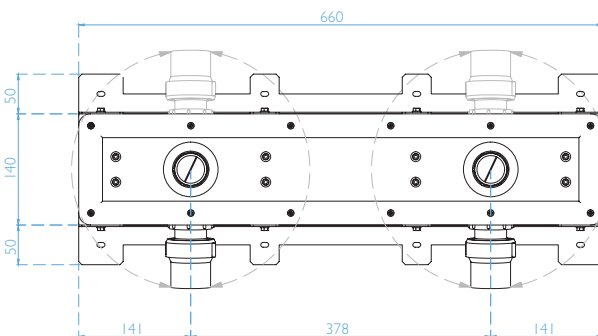

TRIPLE TRAP

