

XTRABACKER

NEW

Universal Tile Backer A high density water resistant construction board suitable for tiles and natural stone.



Supplied with
fixing washers

CCL
BUILDING
PRODUCTS



PRODUCT OVERVIEW

XTRABACKER is manufactured using a high density XPS core, with a specially formulated mineral coating, making it lightweight, easy to handle and trimmable.

In addition to being water resistant, XTRABACKER has excellent thermal properties and compressive strength, making it ideal for use in areas prone to moisture.

BS 5385 Part 1:2008 states that 'tiling directly onto plywood is no longer recommended for wall tiling'

XTRABACKER is ideal for wall tiling as it offers a dimensionally stable wall background which is both strong and moisture resistant.

FEATURES

- Lightweight and Strong
- Water Resistant
- Thermal Protection
- Wall & Floor Solutions
- BS 5385 Part 1:2018
- Fire Resistant Class E
- Lifetime Guarantee
- Trimmable

XTRABACKER provides a superior water resistant substrate preventing moisture absorption and mould growth, the most common cause of tile failure in bathrooms & kitchens.

XTRABACKER can also be used as an alternative to traditional dry lining materials, such as plasterboard.

TESTING

| | |
|-----------------------------|--------------------------|
| Thermal conductivity | 0.037 W/mK |
| Tensile resistance | 0.26 m ² K/W |
| Tensile strength | 0.28 N/mm ² |
| Density | 273.41 Kg/m ³ |
| Compressive strength at 10% | 272 KPa |
| Sheer strength | 801.4 KPa |
| Acoustic absorption | 0.10 a _w |
| Acoustic performance | 0.2 dB |
| Fire Resistant | Class E |
| Load Strength | 100kg |

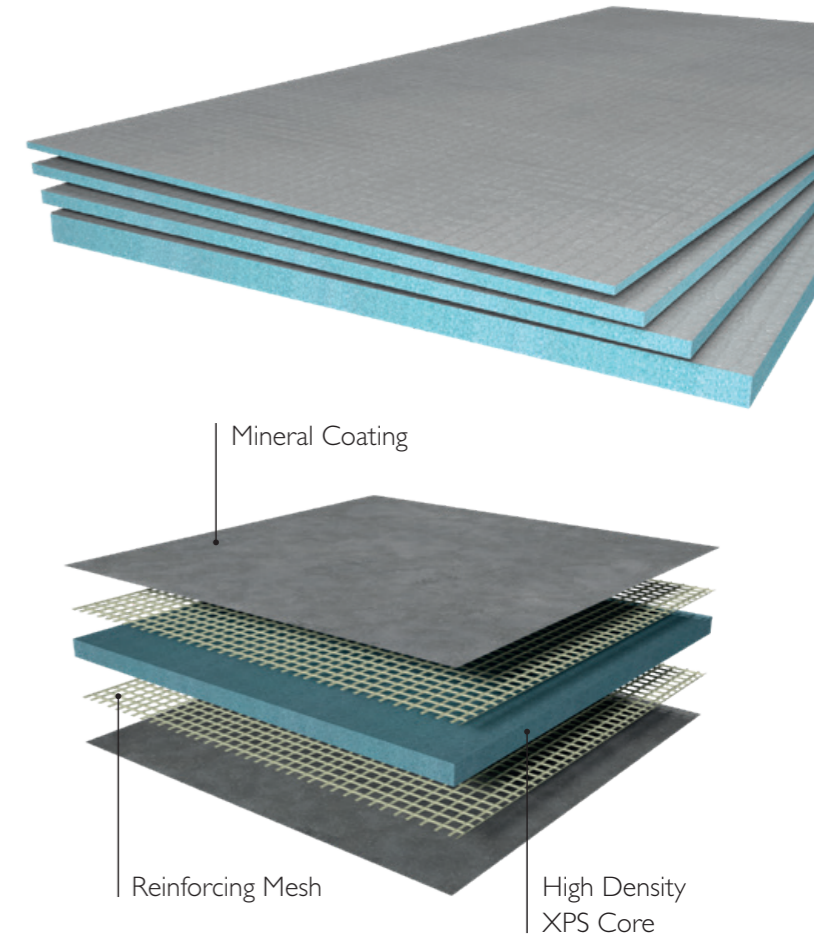

PRODUCT FEATURES



LIGHTWEIGHT



LOAD STRENGTH



WATERPROOF



TRIMMABLE



THERMO INSULATION



XTRABACKER

Universal Tile Backer A high density water resistant construction board suitable for tiles and natural stone.

XTRABACKER BOARD

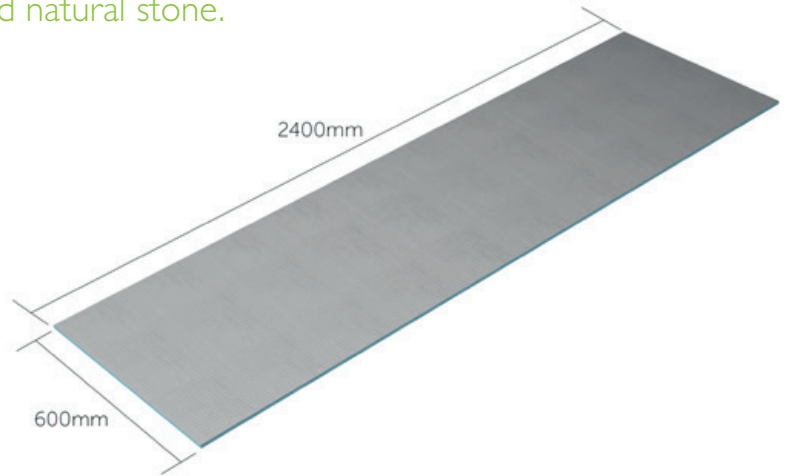
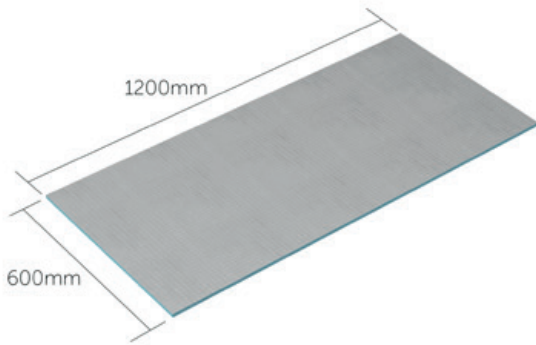

| Length | Width | Thickness | Code | Box Qty |
|--------|-------|-----------|----------|---------|
| 1200mm | 600mm | 6mm | XTB12-06 | 10 |
| 1200mm | 600mm | 10mm | XTB12-10 | 6 |
| 1200mm | 600mm | 12mm | XTB12-12 | 5 |
| 1200mm | 600mm | 20mm | XTB12-20 | 3 |

Supplied with fixing washers

| Length | Width | Thickness | Code | Box Qty |
|--------|-------|-----------|----------|---------|
| 2400mm | 600mm | 10mm | XTB24-10 | 5 |
| 2400mm | 600mm | 12mm | XTB24-12 | 5 |
| 2400mm | 600mm | 20mm | XTB24-20 | 3 |

Supplied with fixing washers

ACCESSORIES



Additional Washers (Pk50) **XTBWA-50**

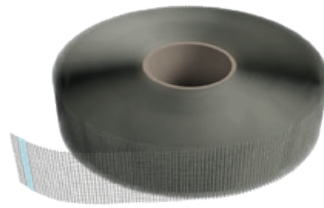

Alkaline Resistant Reinforcing Tape
50mm x 90m **XTBRT-90**

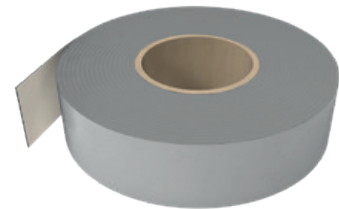

Butyl Self-Adhesive Reinforcing Tape
75mm x 10m **XTBST-10**



CCL Building Products Ltd
Lodge Farm
Hook Road
North Warnborough
Hook
RG29 1HA

Call us now on **0844 327 6002**

info@ccl-wetrooms.co.uk | www.ccl-buildingproducts.co.uk



CCL
BUILDING
PRODUCTS