

XTRABACKER

Universal Tile Backer A high density water resistant construction board suitable for tiles and natural stone.

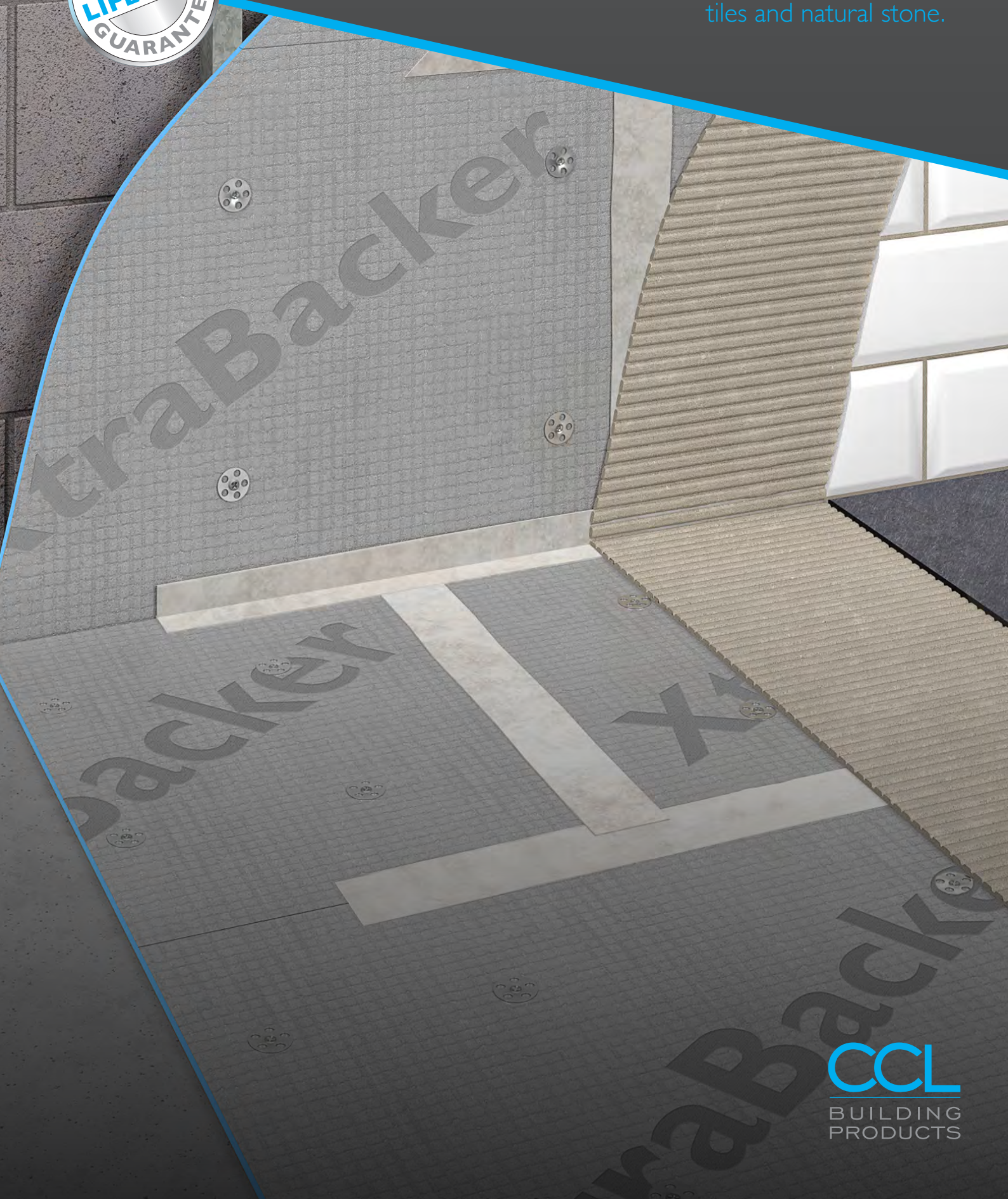

XTRABACKER

PRODUCT OVERVIEW

XTRABACKER is manufactured using a high density XPS core, with a specially formulated mineral coating, making it lightweight, easy to handle and trimmable.

In addition to being water resistant, XTRABACKER has excellent thermal properties and compressive strength, making it ideal for use in areas prone to moisture.

BS 5385 Part 1:2018 states that 'tiling directly onto plywood is no longer recommended for wall tiling'

XTRABACKER is ideal for wall tiling as it offers a dimensionally stable wall background which is both strong and moisture resistant.

FEATURES

- Lightweight and Strong - 100kg/m²
- Water Resistant
- Thermal Protection
- Next Day Delivery †1
- BS 5385 Part 1:2018
- Fire Resistant Class E
- Lifetime Guarantee
- Trimmable

†1 Conditions apply

XTRABACKER provides a superior water resistant substrate preventing moisture absorption and mould growth, the most common cause of tile failure in bathrooms & kitchens.

XTRABACKER can also be used as an alternative to traditional dry lining materials, such as plasterboard.

TESTING

Thermal conductivity	0.037 W/mK
Tensile resistance	0.26 m ² K/W
Tensile strength	0.28 N/mm ²
Density	273.41 Kg/m ³
Compressive strength at 10%	272 KPa
Sheer strength	801.4 KPa
Acoustic absorption	0.10 a _w
Acoustic performance	0.2 dB
Fire Resistant	Class E
Load Strength	100kg

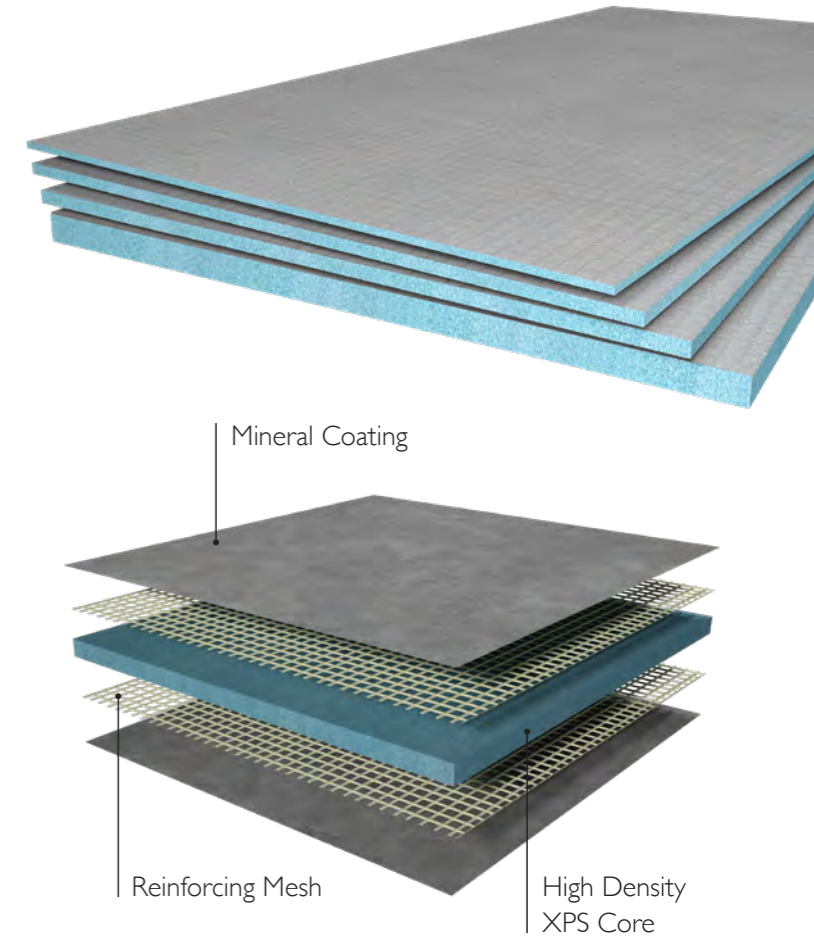

PRODUCT FEATURES



LIGHTWEIGHT



LOAD STRENGTH



WATER RESISTANT



TRIMMABLE



THERMAL INSULATION



FAST DELIVERY



Scan to view XtraBacker Case Study



Scan to view XtraBacker Video

XTRABACKER

Building trust behind every tile

XTRABACKER BOARD

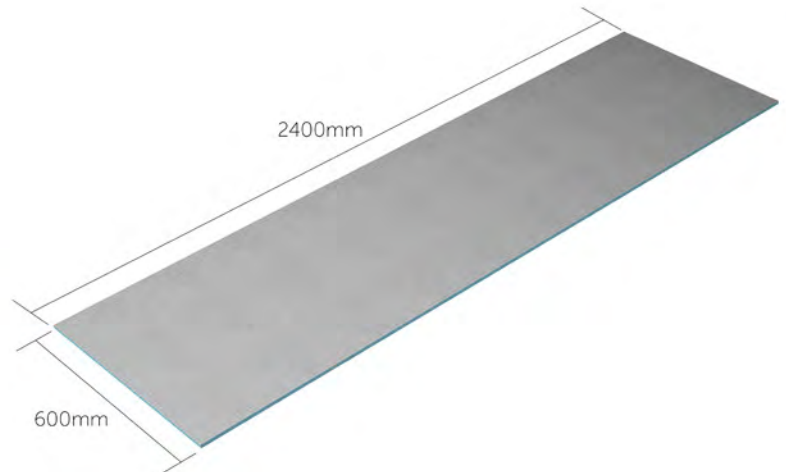
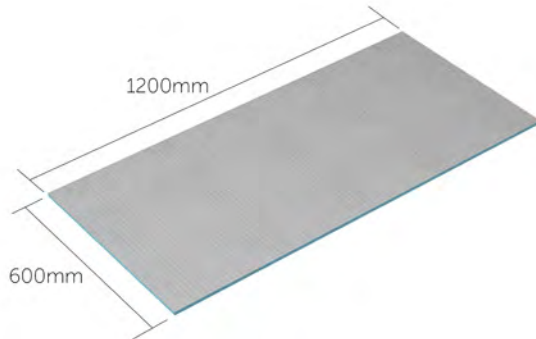

Length	Width	Thickness	Code	Box Qty
1200mm	600mm	6mm	XTB12-06	10
1200mm	600mm	10mm	XTB12-10	6
1200mm	600mm	12mm	XTB12-12	5
1200mm	600mm	20mm	XTB12-20	3

Length	Width	Thickness	Code	Box Qty
2400mm	600mm	6mm	XTB24-06	10
2400mm	600mm	10mm	XTB24-10	5
2400mm	600mm	12mm	XTB24-12	5
2400mm	600mm	20mm	XTB24-20	3

Fixing washers supplied separately | Pallet quantities available upon request | Available boxed or unboxed

ACCESSORIES

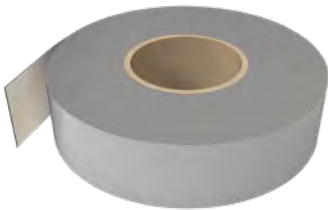

Butyl Self-Adhesive Reinforcing Tape
75mm x 10m XTBST-10



Fleece Waterproofing Tape
120m x 10m XTBF1-10



Washer pack for 1200mm board XTBWA-12

Washer pack for 2400mm board XTBWA-24

Additional Washers (Pk50) XTBWA-50



CCL
BUILDING
PRODUCTS



Call us now on **0344 327 6002**

info@ccl-buildingproducts.co.uk | www.ccl-buildingproducts.co.uk